

---

# BASIC COLLECTION

PRÄSENTATION & VERPACKUNG



**Presentation and packaging** - Presentation at its very best  
**Présentation et emballage** - Présentation de haut niveau

# INHALTSVERZEICHNIS

TABLE OF CONTENTS | TABLE DES MATIÈRES

<b>Standard-Displays   Display series   Présentoirs standard</b>	<b>5</b>
<b>Deko-Serien   Decoration series   Série décoration</b>	<b>9</b>
Vision	10
Kasia	12
Salsa	14
Kariba	16
Tango	18
Grace	20
Passion	21
Arctic	22
Zubehör   Accessories   Accessoires	24
<b>Etui-Serien   Box series   Série écrins</b>	<b>25</b>
Trend	26
Elegance	28
Twist	30
Style	32
Passion	34
<b>Laden-Serien   Tray series   Série plateaux</b>	<b>36</b>
Rebra Extralight System	37
Vario Norm	56
Vario Style	79
Vario Lux	81
Basic Plus	94
<b>Vorlageetuis   Presentation boxes   Écrins de présentation</b>	<b>105</b>
<b>Polytablets   Poly trays   Plateaux en poly</b>	<b>106</b>
<b>Zubehör   Accessories   Accessoires</b>	<b>110</b>
Vorlage-tablets   Presentation trays   Plateaux de présentation	111
Aufmachungskarten   Pads   Cartes	112
Nadeln   Pins   Épingles	119
X-Press-Boxen   X-Press-Boxes   Boîtes coquilles	120
<b>Vitrinen   Showcases   Vitrines</b>	<b>122</b>
<b>Farbtafel   Colour chart   charte de couleurs</b>	<b>132</b>



**KLING GMBH**  
Carl-Benz-Str. 14-16  
75217 Birkenfeld / Germany

Tel.: +49 (0) 7231 4888-0  
Fax: +49 (0) 7231 4888-88  
eMail: service@cling.de

[www.kling.de](http://www.kling.de)



**Deko-Serien**  
ab Seite 9

Decoration Series  
see on page 9

*Série décoration*  
voir page 9

# STANDARD- DISPLAYS

STANDARD DISPLAYS |  
*PRÉSENTOIRS STANDARD*



**Etui-Serien**  
ab Seite 25

Box Series  
see on page 25

*Série écrins*  
voir page 25



**Koffer & Laden Serien**  
ab Seite 36

Cases & Trays Series  
see on page 36

*Série valises et plateaux*  
voir page 36



INDIVIDUAL LOGO PRINTING

COLOUR CHOICE

INTERCHANGEABLE IMAGE

ORDERS OF 50 PIECES APPLY

Lackierung nach dem RAL-Farbspektrum möglich.

Possible colours selectable from the RAL spectrum

Couleur des éléments à sélectionner dans le nuancier RAL

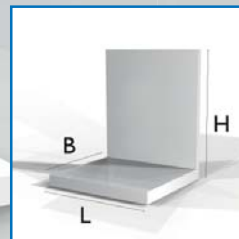

## MARKENWELTEN

Schlichte Eleganz mit der Konzentration auf das Wesentliche - das sind die neuen Marken-Displays für Ihren Auftritt am PoS. Kommunizieren Sie die Einmaligkeit Ihrer Marke und setzen Sie Ihre Ware aufmerksamkeitsstark in Szene. Mit den Standarddisplays von Kling gelingt Ihnen das ohne Aufwand und zu vernünftigen Preisen bei geringen Abnahmemengen. Dabei haben Sie die Wahl zwischen 3 vorgegeben Größen und einer attraktiven Farbauswahl für die Lackierung in Hochglanz oder matt. Gerne zeigen wir Ihnen die Möglichkeiten der Anbringung Ihres Markennamens oder Logos sowie die Ausstattung mit einzelnen Aufstellern und Dekorationen. Profitieren Sie von unserer Erfahrung im Displaybau!

Simple elegance with a clear focus on the essentials! These are the key attributes of our new customised displays to be presented at point of sale. Communicate the uniqueness of your brand and focus all attention on your products. With the new standard displays from Kling, you will succeed in doing both - with very little effort, at reasonable prices and with low order quantities. You have the choice between three predefined sizes and an attractive choice of colors in both glossy or matt finishes. We would love to show you the different possibilities of branding your brand name or logo, as well as the possible accessories of individual display stands and decorations. Benefit from our experience!

De la simplicité, de l'élégance, ce sont ainsi les caractéristiques principales de nos nouveaux présentoirs dédiés aux points de vente. Votre marque est unique: mettez-la donc parfaitement en scène à l'aide de nos modèles de présentoirs KLING à des prix et des minima de commande raisonnables. Vous avez le choix entre 3 hauteurs définies et une large palette de couleurs pour un laquage en finition brillante ou mate.

Profitez de notre expérience et de notre savoir-faire dans la mise en scène d'une marque ou d'un logo pour une présentation exclusive de vos produits!

Maßangaben: Länge x Breite x Höhe | Dimensions: Length x Width x Height | Dimensions: Longueur x Largeur x Hauteur

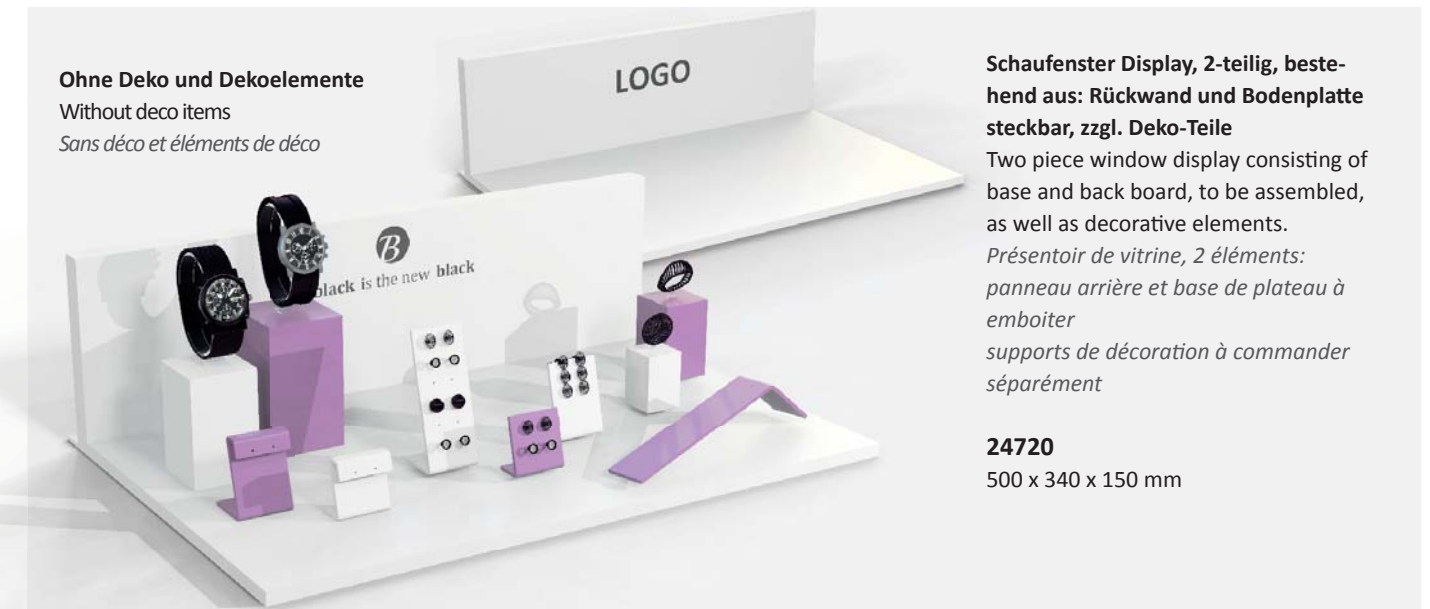

Ohne Deko und Dekoelemente

Without deco items

Sans déco et éléments de déco

Schaufenster Display, 2-teilig, bestehend aus: Rückwand und Bodenplatte steckbar, zzgl. Deko-Teile

Two piece window display consisting of base and back board, to be assembled, as well as decorative elements.

Présentoir de vitrine, 2 éléments: panneau arrière et base de plateau à emboîter supports de décoration à commander séparément

24720

500 x 340 x 150 mm

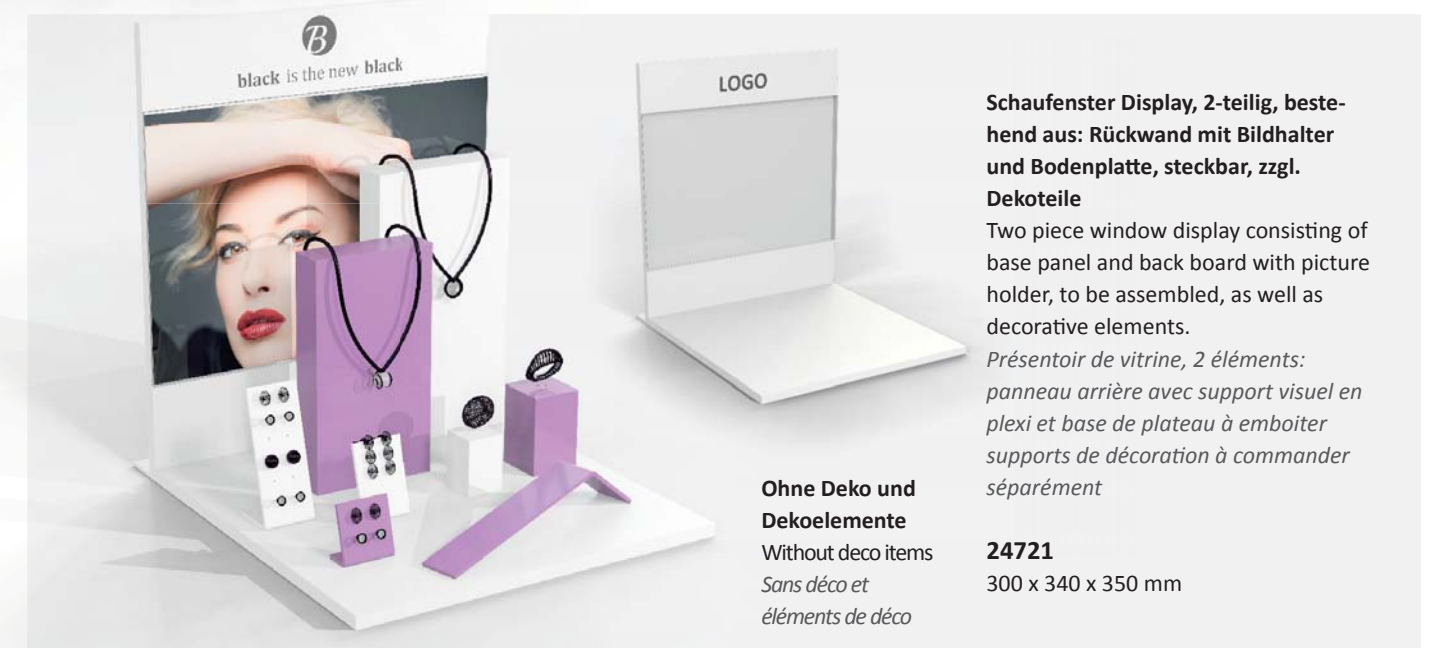

black is the new black

LOGO

Schaufenster Display, 2-teilig, bestehend aus: Rückwand mit Bildhalter und Bodenplatte, steckbar, zzgl. Dekoteile

Two piece window display consisting of base panel and back board with picture holder, to be assembled, as well as decorative elements.

Présentoir de vitrine, 2 éléments: panneau arrière avec support visuel en plexi et base de plateau à emboîter supports de décoration à commander séparément

Ohne Deko und Dekoelemente

Without deco items

Sans déco et éléments de déco

24721

300 x 340 x 350 mm

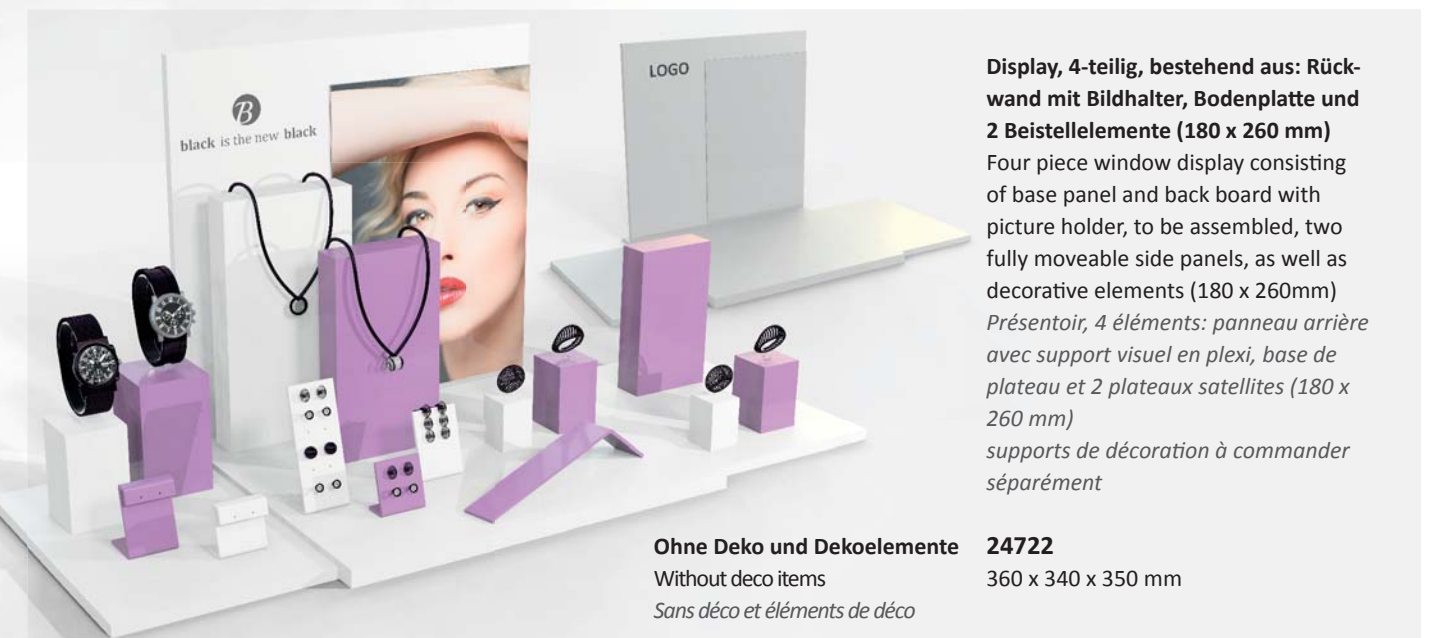

black is the new black

LOGO

Display, 4-teilig, bestehend aus: Rückwand mit Bildhalter, Bodenplatte und 2 Beistellelemente (180 x 260 mm)

Four piece window display consisting of base panel and back board with picture holder, to be assembled, two fully moveable side panels, as well as decorative elements (180 x 260mm)

Présentoir, 4 éléments: panneau arrière avec support visuel en plexi, base de plateau et 2 plateaux satellites (180 x 260 mm) supports de décoration à commander séparément

Ohne Deko und Dekoelemente

Without deco items

Sans déco et éléments de déco

24722

360 x 340 x 350 mm

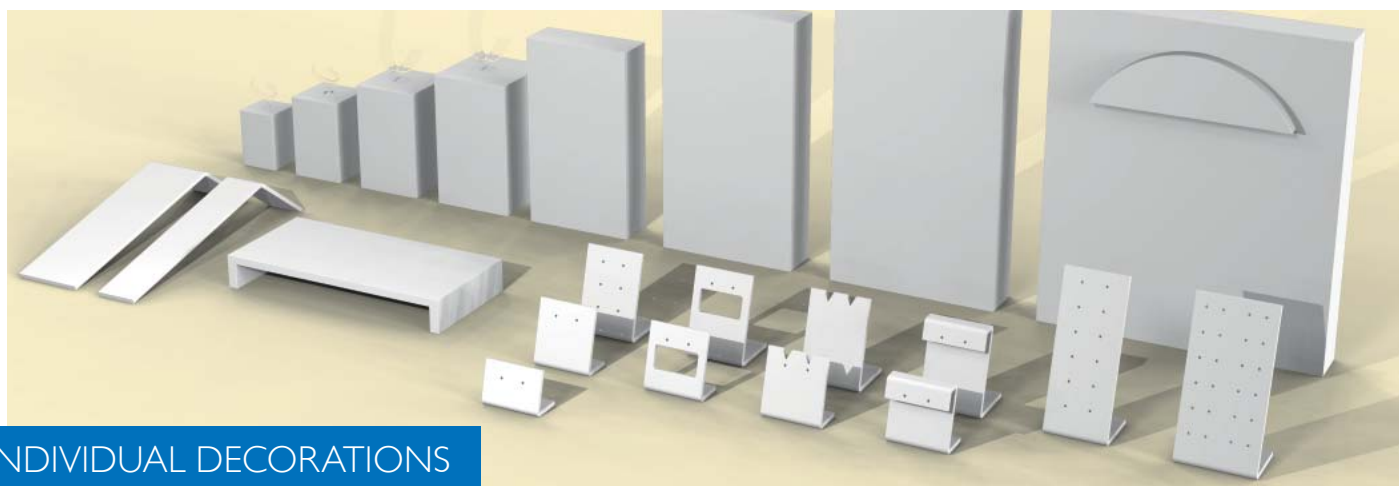
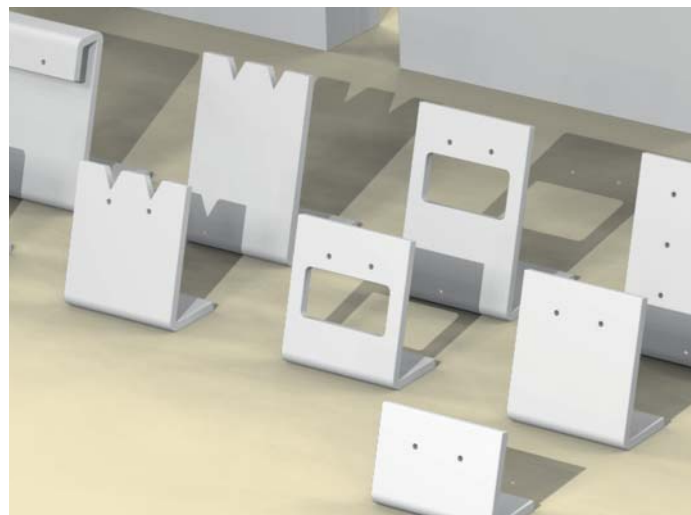
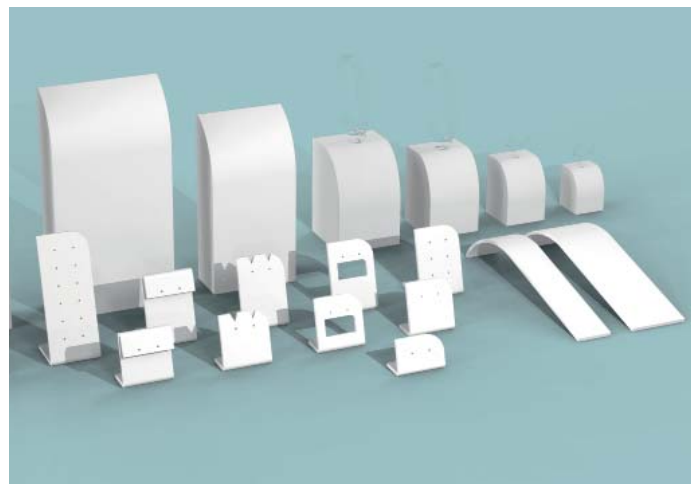

INDIVIDUAL DECORATIONS

SET PRICE ON REQUEST

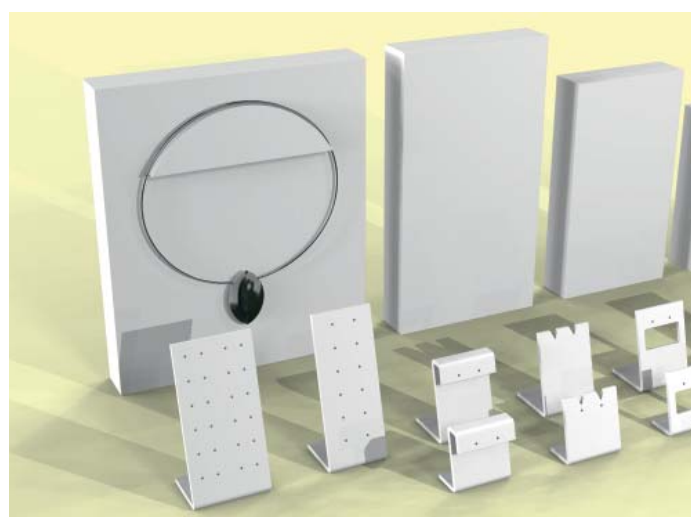

# DEKO-SERIEN

DECORATION SERIES | *SÉRIE DÉCORATION*

**Vision** 10 - 11

**Kasia** 12 - 13

**Salsa** 14 - 15

**Kariba** 16 - 17

**Tango** 18 - 19

**Grace & Passion** 20 - 21

**Arctic** 22 - 23

**Zubehör | Accessories | Accessoires** 24



Maßangaben: Länge x Breite x Höhe | Dimensions: Length x Width x Height | Dimensions: Longueur x Largeur x Hauteur



**Deko-Büste Vision**  
 Decoration bust Vision  
 Buste déco Vision

- DE63B1** 150 x 100 x 350 mm
- DE63B2** 150 x 100 x 280 mm
- DE63B3** 150 x 100 x 210 mm

## SERIE VISION

Die neue Dekoserie besticht vor allem durch Ihr innovatives und modernes Design - damit sorgen Sie für eine ansprechende und aufmerksamkeitsstarke Präsentation am Point of Sale. Diese Dekoserie besteht aus lackiertem Gießharz.

This new series dazzles with its innovative and modern design, ensuring your attractive and eye-catching product presentation at each point of sale. These display elements are made of cast resin and finished in elegant lacquer finish.

La nouvelle collection de bustes éblouit avant tout par son design innovatif et moderne rendant votre présentation attrayante et attirant l'attention du consommateur sur chaque point de vente. Cette collection de décoration est en résine moulée laquée.

### Farben / Colours / Coloris:

weiß matt / white mat / blanc mat    schwarz matt / black mat / noir mat



**Deko-Aufsteller Vision für Ringe (Tetraederform)**  
 Stand Vision for rings (Tetrahedron shaped)  
 Présentoir déco Vision pour bague (en forme de tétraèdre)

- DE63R1**  
45 x 60 mm



**Deko-Aufsteller Vision für Ringe (Tetraederform)**  
 Stand Vision for rings (Tetrahedron shaped)  
 Présentoir déco Vision pour bague (en forme de tétraèdre)

- DE63R2**  
35 x 50 mm



**Deko-Sockel Vision**  
 Base Vision  
 Socle déco Vision

- DE63S2**  
Ablagefläche 50 x 50 mm  
 Decoration surface 50 x 50 mm  
 Surface de présentation, 50x50mm

71 x 71 x 60 mm



**Deko-Sockel Vision**  
 Base Vision  
 Socle déco Vision

- DE63S1**  
Ablagefläche 80 x 80 mm  
 Decoration surface 80 x 80 mm  
 Surface de présentation, 80x80mm

113 x 113 x 70 mm



**Deko-Aufsteller Vision für Ohrhänge**  
 Stand Vision for earrings  
 Présentoir déco Vision pour B.O.

- DE63O2**  
40 x 30 x 50 mm



**Deko-Aufsteller Vision für Ohrhänge**  
 Stand Vision for earrings  
 Présentoir déco Vision pour B.O.

- DE63O1**  
50 x 40 x 75 mm

FROM STOCK

SILKY & NON-SLIP SURFACE

## SERIE KASIA

Die neue Dekoserie Kasia bereichert das bestehende Sortiment nicht nur mit ihrem Namen, sondern auch mit ihrer Eleganz und der edlen Erscheinung. Der neuartige Bezug der Büsten bildet eine seidig anmutende Oberfläche, die leicht glänzend und zugleich griffig ist und somit Schmuckstücke nicht verrutschen lässt. Die Serie Kasia bietet eine große Auswahl an unterschiedlichen Elementen, die passend zum Schmucksortiment frei kombinierbar sind. In Champagner, Braun und Schwarz lieferbar.

The new Kasia decor series enhances the existing ranges, not only with its resonant name, but also with its elegant appearance. The unique covering on the busts and presentation elements offers a silky, slightly shiny surface which is slightly textured, rendering the surface non-slip, and ensuring that the pieces of jewellery do not slip or slide out of place. The Kasia series is available in black, dark brown as well as champagne white and provides the ideal background for the sophisticated presentation of high-valued jewellery pieces.

La nouvelle série déco Kasia enrichit la gamme existante, non seulement par son nom, mais aussi par son élégance et son apparence raffinée. Le nouveau revêtement des bustiers d'aspect soyeux, légèrement brillant tout en ayant du toucher, ne laisse ainsi glisser les bijoux. La série Kasia disponible dans les couleurs noir, marron foncé et champagne clair est l'arrière-plan idéal pour la présentation de bijoux de valeur et offre un vaste choix d'éléments différents que l'on peut librement assortir à la gamme de bijoux.

Dekoartikel auf [www.mondecor-shop.de](http://www.mondecor-shop.de)

### Farben / Colours / Coloris:



Maßangaben: Länge x Breite x Höhe |  
Dimensions: Length x Width x Height |  
Dimensions: Longueur x Largeur x Hauteur

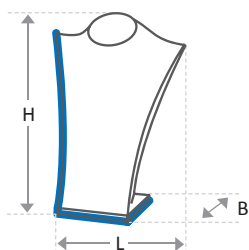

**Deko-Büste Kasia**  
Decoration bust Kasia  
Buste déco Kasia

**DE62B1**  
135 x 120 x 255 mm

**DE62B2**  
120 x 100 x 205 mm

**DE62B3**  
105 x 90 x 158 mm



**Deko-Büste Kasia**  
Decoration bust Kasia  
Buste déco Kasia

**DE62B6**  
155 x 90 x 255 mm

**DE62B7**  
135 x 80 x 200 mm

**DE62B8**  
125 x 72 x 150 mm

Maßangaben: Länge x Breite x Höhe | Dimensions: Length x Width x Height | Dimensions: Longueur x Largeur x Hauteur



**Deko-Aufsteller Kasia für Ohrringe**  
Stand Kasia for earrings  
Présentoir déco Kasia pour B.O.

**DE62O1**  
62 x 70 mm

**DE62O2**  
62 x 105 mm



**Deko-Aufsteller Kasia für Ohrringe**  
Stand Kasia for earrings  
Présentoir déco Kasia pour B.O.

**DE62O6**  
35 x 30 x 40 mm



**Deko-Aufsteller Kasia für Ohrringe**  
Stand Kasia for earrings  
Présentoir déco Kasia pour B.O.

**DE62O5**  
50 x 50 x 80 mm

**DE62O4**  
50 x 50 x 65 mm

**DE62O3**  
50 x 50 x 55 mm



**Deko-Aufsteller Kasia für Anhänger mit Kette**  
Stand Kasia for pendant with chain  
Présentoir déco Kasia pour pendentif avec chaîne

**DE62K7**  
40 x 32 x 40 mm

**DE62K8**  
62 x 52 x 65 mm



**Deko-Aufsteller Kasia für Uhr**  
Stand Kasia for watch  
Présentoir déco Kasia pour montre

**DE62U1**  
45 x 60 x 125 mm

**DE62U2**  
45 x 60 x 135 mm



**Deko-Aufsteller Kasia für Ringe**  
Stand Kasia for single ring  
Présentoir déco Kasia pour bague

**DE62R3**  
H/∅: 68 x 50 mm

**DE62R2**  
H/∅: 50 x 50 mm

**DE62R1**  
H/∅: 42 x 50 mm



**Armbandwelle Kasia mit Gummi**  
Bracelet "wave" Kasia with elastic  
Support bracelet Kasia avec élastique

**DE62A1**  
30 x 200 x 45 mm



**Deko-Kissen Kasia**  
Cushioned pillow Kasia  
Coussinet rembourré Kasia

**DE62K1**  
85 x 85 mm

**DE62K2**  
100 x 100 mm

SERIE SALSA

Die klassische Deko-Serie – sie ist die Basis für eine überzeugende Präsentation Ihrer Ware im Schaufenster und in der Vitrine. Die perfekte Verarbeitung und der günstige Preis sind nicht die einzigen Argumente, die diese Serie seit Jahren zum Bestseller machen. Die Serie Salsa ist mit hochwertigem Kunstleder bezogen und in Schwarz und Weiß ab Lager lieferbar.

This classic decoration series forms the basis for the compelling presentation of your jewellery pieces - both in the shop window as well as in the showcase. Excellent workmanship and affordable pricing are features which have made this series a bestseller for several years. The Salsa series is covered in high quality leatherette and is readily available from stock in either black or white.

La série déco classique - c'est la base d'une présentation convaincante de vos articles en vitrine. Ses finitions parfaites et son prix abordable ne sont pas les seules raisons, pour lesquelles cette série est un bestseller depuis des années. La série Salsa est gainée de cuir synthétique de qualité et est disponible en stock en noir et blanc.

Maßangaben: Länge x Breite x Höhe |  
Dimensions: Length x Width x Height |  
Dimensions: Longueur x Largeur x Hauteur

Farben / Colours / Coloris:

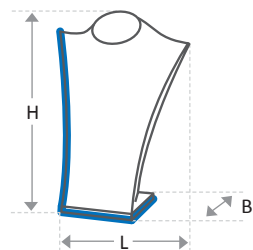

FROM STOCK

Dekoartikel auf [www.mondecor-shop.de](http://www.mondecor-shop.de)

**Deko-Büste Salsa**  
Decoration bust Salsa  
*Buste déco Salsa*

**DE30B5**  
200 x 130 x 305 mm

**DE30B1**  
200 x 160 x 200 mm

**DE30B2**  
180 x 145 x 180 mm

**DE30B3**  
150 x 125 x 150 mm

**Deko-Büste Salsa, liegend**  
Decoration bust Salsa, flat  
*Buste déco Salsa à plat*

**DE30B4**  
100 x 175 x 105 mm

Maßangaben: Länge x Breite x Höhe | Dimensions: Length x Width x Height | Dimensions: Longueur x Largeur x Hauteur

**Deko-Aufsteller Salsa für Ohrringe**  
Stand Salsa for earrings  
*Présentoir déco Salsa pour B.O.*

**DE30O1**  
65 x 60 mm

**DE30O2**  
55 x 50 mm

**DE30O3**  
45 x 40 mm

**DE30O4**  
40 x 42 mm

**Deko-Aufsteller Salsa für 1 Ring**  
Stand Salsa for single ring  
*Présentoir déco Salsa pour bague*

**DE30R1**  
65 x 40 mm

**DE30R2**  
55 x 40 mm

**DE30R3**  
40 x 40 mm

**Deko-Aufsteller Salsa für 2 Ringe (versetzt angeordnet)**  
Stand Salsa for 2 rings  
*Présentoir déco Salsa*

**DE30R1T**  
H: 95 mm

**DE30R3TR**  
H: 65 mm

**Deko-Aufsteller Salsa, mit Gummihalterung für Kette**  
Stand Salsa for pendant with chain, with elastic  
*Présentoir déco Salsa avec élastique pour pendentif avec chaîne*

**DE30C1**  
70 x 50 mm

**DE30C2**  
50 x 45 mm

**DE30C3**  
45 x 50 mm

**Deko-Aufsteller Salsa für Uhr, quer**  
Horizontal stand Salsa for watch  
*Présentoir horizontal déco Salsa pour montre*

**DE30U1Q**  
75 x 75 x 40 mm

**Deko-Aufsteller Salsa für Uhr, hoch**  
Upright stand Salsa for watch  
*Présentoir vertical déco Salsa pour montre*

**DE30U1H**  
75 x 75 x 100 mm

**Deko-Kissen Salsa**  
Cushioned pillow Salsa  
*Coussinet rembourré Salsa*

**DE30K1**  
85 x 70 mm

**Armbandwelle Salsa mit Gummi**  
Bracelet "wave" Salsa with elastic  
*Support bracelet Salsa avec élastique*

**DE30A1**  
200 x 40 mm

**DE30A2**  
195 x 26 mm

**Deko-Sockel Salsa**  
Plinth Salsa  
*Socle déco Salsa*

**DE30S2**  
235 x 175 x 20 mm

**DE30S1**  
400 x 300 x 40 mm



SERIE KARIBA

Mehr Vielfalt finden Sie bei keiner Deko-Serie! Elegant und edel verarbeitet, mit einer außergewöhnlichen Auswahl an Büsten und Aufstellern, sind Ihnen bei der Präsentation Ihrer Kollektionen fast keine Grenzen gesetzt. Diese Serie eignet sich auch für größere Schmuckstücke und längere Ketten. Die Elemente der Serie Kariba sind mit einem edlen Bezugsstoff bespannt und in den Farben Weiß und Braun ab Lager lieferbar.

No other Decoration series offers as much diversity! Elegant finishes with an extraordinary selection of busts and displays to allow you to present your jewellery collections without limits. This series is also suitable for larger pieces, or for longer necklaces. The Kariba series is covered with luxurious textile and is available in stock in white and brown.

Aucune autre série déco n'offre autant de diversité! Des finitions élégantes et nobles et une sélection exceptionnelle de bustes et de présentoirs vous octroient une présentation sans limite de vos collections. Cette série convient également aux bijoux de plus grandes tailles et aux colliers très longs. Les éléments de la série „Kariba“ sont gainés de tissus nobles et sont disponibles en stock en blanc et marron.

Farben / Colours / Coloris:

weiß / white / blanc braun / brown / marron

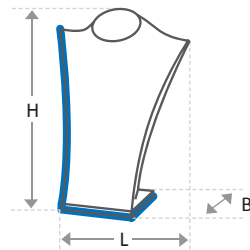

Maßangaben: Länge x Breite x Höhe |  
Dimensions: Length x Width x Height |  
Dimensions: Longueur x Largeur x Hauteur

FROM STOCK

Dekoartikel auf [www.mondecor-shop.de](http://www.mondecor-shop.de)

Maßangaben: Länge x Breite x Höhe | Dimensions: Length x Width x Height | Dimensions: Longueur x Largeur x Hauteur

**Deko-Aufsteller Kariba für Ketten**  
Stand Kariba for necklace  
*Présentoir déco Kariba pour chaîne*

**DE42C1** 70 x 60 x 120 mm  
**DE42C2** 70 x 50 x 85 mm  
**DE42C3** 50 x 40 x 65 mm

**Deko-Aufsteller Kariba für 1 Ring**  
Stand Kariba for single ring  
*Présentoir déco Kariba pour bague*

**DE42R1** 43 x 43 x 25 mm  
**DE42R2** 43 x 43 x 48 mm  
**DE42R3** 43 x 43 x 73 mm

**Armbandwelle Kariba mit Gummi**  
Bracelet "wave" Kariba with elastic  
*Support bracelet Kariba avec élastique*

**DE42A1** L: 190 mm

**Deko-Kissen Kariba**  
Pillow Kariba  
*Coussinet rembourré Kariba*

**DE42K1** 120 x 120 mm  
**DE42K2** 90 x 90 mm

**Deko-Aufsteller Kariba für Uhr, hoch**  
Upright stand Kariba for watch  
*Présentoir vertical déco Kariba pour montre*

**DE42U1H** Ø: 60 mm

**Deko-Aufsteller Kariba für Uhr, quer**  
Horizontal stand Kariba for watch  
*Présentoir horizontal déco Kariba pour montre*

**DE42U2Q** Ø: 60 mm

**Deko-Grundplatte Kariba**  
Base Kariba  
*Base déco Kariba*

**DE42S3** 225 x 225 x 38 mm  
**DE42S2** 273 x 361 x 114 mm  
**DE42S1** 438 x 456 x 60 mm

**Deko-Sockel Kariba**  
Base Kariba  
*Base déco Kariba*

**DE42S4** 150 x 120 x 45 mm

**Deko-Büste Kariba**  
Decoration bust Kariba  
*Buste déco Kariba*

**DE42B5**  
265 x 245 x 490 mm

**DE42B1**  
210 x 170 x 345 mm

**DE42B2**  
200 x 145 x 290 mm

**DE42B3**  
150 x 115 x 230 mm

**DE42B4**  
110 x 85 x 180 mm

**Deko-Aufsteller Kariba für Bügelohrringe**  
Stand Kariba for Creole Earrings  
*Présentoir déco Kariba pour créoles*

**DE42O4**  
52 x 65 x 104 mm

**Deko-Aufsteller Kariba für Ohrringe**  
Stand Kariba for earrings  
*Présentoir déco Kariba pour B.O.*

**DE42O1**  
55 x 55 x 105 mm

**DE42O2**  
55 x 40 x 63 mm

SERIE TANGO

Ausschließlich in Weiß erhältlich und mit einem festen Kunstleder bespannt, besticht diese Serie durch eine perfekte handwerkliche Verarbeitung und der überzeugenden Präsentation Ihrer Ware. Die große Auswahl an unterschiedlichen Größen der einzelnen Büsten und Aufsteller lässt umfangreiche Deko-Landschaften zu, sowohl in der klassischen Schaufenstergestaltung, als auch bei platzsparenden Vitrinen-Dekorationen.

Only available in white and covered in a durable leatherette, this series impresses with high quality craftsmanship and the convincing presentation of your jewellery pieces. The wide range of various bust sizes and displays allows you to create a variety of visual landscapes in both the window display space and within cabinet showcases.

Exclusivement disponible en blanc et gainée d'un cuir synthétique résistant, cette série séduit par ses finitions artisanales parfaites et par la présentation convaincante de vos articles. Le grand choix de tailles des différents bustes et présentoirs permet de créer de vastes univers décoratifs, aussi bien en vitrine que sur des étalages.

Maßangaben: Länge x Breite x Höhe | Dimensions: Length x Width x Height | Dimensions: Longueur x Largeur x Hauteur

Farben / Colours / Coloris:

weiß / white / blanc

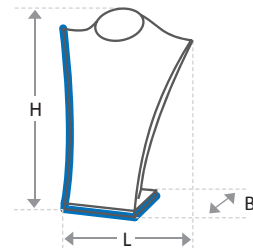

FROM STOCK

Dekoartikel auf [www.mondecor-shop.de](http://www.mondecor-shop.de)

**Deko-Büste Tango mit Klettbandhalterung**  
 Decoration bust Tango with velcro support  
*Présentoir déco Tango avec support velcro*

**DE34B5** 210 x 125 x 235 mm  
**DE34B1** 190 x 130 x 215 mm  
**DE34B2** 200 x 115 x 155 mm

**Deko-Aufsteller Tango für Ohrringe**  
 Stand Tango for earrings  
*Présentoir déco Tango pour B.O.*

**DE34O1** 45 x 45 x 70 mm  
**DE34O2** 45 x 45 x 60 mm

**Deko-Aufsteller Tango für Ohrringe**  
 Stand Tango for earrings  
*Présentoir déco Tango pour B.O.*

**DE34O3** 40 x 35 x 60 mm  
**DE34O4** 44 x 34 x 34 mm  
**DE34O5** 27 x 27 x 30 mm

Maßangaben: Länge x Breite x Höhe | Dimensions: Length x Width x Height | Dimensions: Longueur x Largeur x Hauteur

**Deko-Aufsteller Tango für Anhänger mit Kette**  
 Deco stand Tango for necklace  
*Présentoir déco Tango pour chaîne*

**DE34C1** 85 x 63 x 105 mm  
**DE34C2** 80 x 60 x 82 mm  
**DE34C3** 72 x 55 x 68 mm  
**DE34C4** 52 x 35 x 50 mm  
**DE34C5** 40 x 45 x 33 mm  
**DE34C6** 45 x 27 x 40 mm

**Deko-Aufsteller Tango für 1 Ring**  
 Stand Tango for single ring  
*Présentoir déco Tango pour bague*

**DE34R1** 40 x 40 x 70 mm  
**DE34R2** 40 x 40 x 55 mm  
**DE34R3** 40 x 40 x 40 mm

**Armbandwelle Tango**  
 Bracelet "wave" Tango  
*Support bracelet Tango*

**DE34A1** 200 x 30 x 35 mm

**Deko-Aufsteller Tango für Uhr, hoch**  
 (Spange: H/B 70x15 mm)  
 Upright stand Tango for watch  
 (support : H/W 70x15 mm)  
*Présentoir vertical déco Tango pour montre*  
 (support : H/LA 70x15 mm)

**DE34U1** 53 x 60 x 105 mm

**Deko-Aufsteller Tango für Uhr, quer**  
 (Spange: L/B 60x10 mm)  
 Horizontal stand Tango for watch  
 (support L/W 60x10 mm)  
*Présentoir horizontal déco Tango pour montre*  
 (support : L/LA 60x10 mm)

**DE34U2** 50 x 60 x 60 mm

**Deko-Welle Tango für Collier oder Armband**  
 Deco "Wave" Tango for bracelet or necklace  
*Vague déco Tango pour collier ou bracelet*

**DPW1U** 205 x 190 x 40 mm

**Deko-Sockel Tango**  
 Deco plinth Tango  
*Socle déco Tango*

**DE34S1B** 220 x 220 x 75 mm  
**DE34S2A** 130 x 130 x 50 mm  
**DE34S1A** 220 x 220 x 35 mm

## SERIE GRACE

Eine extravagante Formensprache und die samtweiche Oberfläche der Büsten und Aufsteller unterstreichen den luxuriösen Anspruch der hochwertigen Kollektionen. Damit überzeugen Sie Ihre anspruchsvolle Kundschaft und glänzen mit einer exklusiven Dekoration. Alle Teile sind aus hochwertigem Resine einzeln von Hand gefertigt und mit Softouch-Lack veredelt. Die Serie ist in 2 Farben ab Lager lieferbar.

This high-quality collection flaunts an extravagant design language and features a velvety surface to the busts and display stands. The exclusive Grace series is made of high quality resin, individually handcrafted and finished with Soft-Touch lacquer varnish. Allow your jewellery to shine with this series which is available from stock either White or Black.

*Un langage extravagant des formes et la surface douce des bustes et des présentoirs soulignent l'exigence luxueuse des collections haut de gamme. Vous allez ainsi convaincre et impressionner votre clientèle exigeante avec une décoration exclusive. Toutes les pièces sont fabriquées en résine de grande qualité, laquées et fabriquées à la main. La série est disponible en stock en deux couleurs, blanc et noir.*

**Maßangaben: Länge x Breite x Höhe |**  
Dimensions: Length x Width x Height |  
Dimensions: Longueur x Largeur x Hauteur

**Farben / Colours / Coloris:**

weiß / white / blanc    schwarz / black / noir

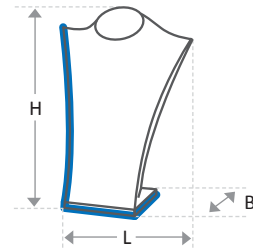

Dekoartikel auf [www.mondecor-shop.de](http://www.mondecor-shop.de)



**Deko-Büste Grace**  
Decoration bust Grace  
Buste déco Grace

**DE56/1** 160 x 160 x 355 mm

**DE56/2** 140 x 140 x 295 mm

**DE56/3** 105 x 105 x 230 mm

**DE56/17** 72 x 72 x 155 mm

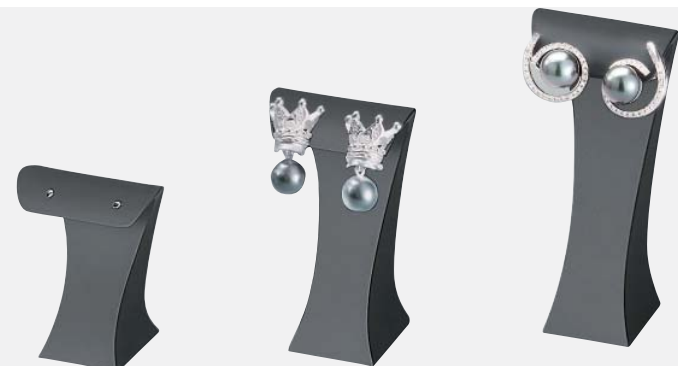

**Deko-Aufsteller Grace für Ohrringe**  
Stand Grace for earrings  
Présentoir déco Grace pour B.O.

**DE56/16** 40 x 30 x 53 mm

**DE56/15** 40 x 30 x 70 mm

**DE56/14** 40 x 30 x 90 mm

**Maßangaben: Länge x Breite x Höhe |** Dimensions: Length x Width x Height | *Dimensions: Longueur x Largeur x Hauteur*



**Deko-Sockel Grace**  
Deco plinth Grace  
Socle déco Grace

**DE56/4** 280 x 170 x 20 mm

**DE56/5** 205 x 108 x 45 mm



**Deko-Tisch Grace mit 3 abgerundeten Ecken**  
Deco Base Grace with 3 edges rounded off  
Table déco Grace avec 3 coins arrondis

**DE56/6** 185 x 160 x 35 mm



**Deko-Tisch Grace, rund**  
Deco Base Grace, round  
Table déco Grace, ronde

**DE56/7** Ø/H: 90/60 mm



**Armbandwelle Grace**  
Bracelet "wave" Grace  
Support bracelet Grace

**DE56/8** 200 x 38 x 34 mm



**Deko-Sockel Grace mit Loch, zzgl. Halter**  
Deco Plinth Grace with hole, excl. ring holder  
Socle déco Grace avec perforation, support bague à commander séparément

**DE56/12** Ø/H: 40/50 mm

**DE56/11** Ø/H: 40/73 mm

**DE56/13** Ø/H: 40/32 mm

**DE56/10** Ø/H: 50/60 mm

**DE56/9** Ø/H: 50/36 mm

Ringhalter und Spangen siehe Seite 24 | Ring Holder and C-Clips on page 24 | *Support bague et C-Clips page 24*

## PASSION

Passend zu den Aufstellern der Serie Grace sind die Büsten Passion eine neue Design-Linie, die mit ihrer Klarheit und der akkuraten Formensprache eine zeitgemäße Schmuckdekoration leicht macht. Auch diese Büsten überzeugen mit einer samtweichen Oberfläche. Lieferbar in Schwarz und Weiß.

*Assortis aux présentoirs de la série „Grace“, les bustes „Passion“ font partie d'une nouvelle ligne de design qui permet une décoration moderne de bijoux grâce à sa clarté et à son langage formel adapté. Ces bustes savent également convaincre par une surface d'une douceur velours et sont disponibles en noir et blanc départ usine.*

The Passion busts, a new design line, are fully compatible with the Grace series. Their contemporary lines and styling feature velvety-soft surfaces and this series is available from stock in either black and white.

**Farben / Colours / Coloris:**

weiß / white / blanc    schwarz / black / noir



**Deko-Büste Passion**  
Decoration bust Passion  
Buste déco Passion

**DE61B1** 225 x 160 x 450 mm

**DE61B2** 190 x 140 x 370 mm

**DE61B3** 160 x 110 x 300 mm

**DE61B4** 125 x 95 x 230 mm

**DE61B5** 82 x 65 x 160 mm

## SERIE ARCTIC

Zeitlos und elegant – die Klarheit der gefrosteten Oberflächen lässt Farbsteine besonders intensiv strahlen und edle Schmuckstücke kommen auffallend plastisch zur Geltung. Die fließenden Formen der Büsten und Aufsteller nehmen die Präsenz der Dekoration bewusst zurück und lassen jedes Stück der präsentierten Ware in den Vordergrund treten.

Timeless and elegant – the clarity of the frosted surfaces allows coloured stones to shine intensely and fine jewellery shown to advantage. The flowing forms of the busts and display stands deliberately take the back seat, allowing each of the jewellery pieces presented to come to the foreground.

*Intemporel et élégant – la clarté des surfaces à effet glacé fait rayonner de manière particulièrement intense les pierres de couleur et font ressortir l'esthétisme des bijoux. Les formes fluides des bustes et des présentoirs mettent en avant chaque bijou présenté, la décoration étant volontairement reléguée au second plan.*

**Material: Plexi** | Material: Acrylic | *Matériel: Plexi*

**Maßangaben: Länge x Breite x Höhe** | Dimensions: Length x Width x Height | *Dimensions: Longueur x Largeur x Hauteur*

**Farben** | Colours | *Coloris:*

gefrostet | frosted | *givré*

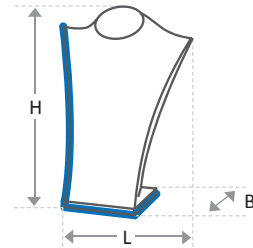

Dekoartikel auf [www.mondecor-shop.de](http://www.mondecor-shop.de)



**Maßangaben: Länge x Breite x Höhe** | Dimensions: Length x Width x Height | *Dimensions: Longueur x Largeur x Hauteur*

**Deko-Aufsteller Arctic für Ohrringe**  
Stand Arctic for earrings  
*Présentoir déco Arctic pour B.O.*

**7C/ST1** 30 x 25 x 35 mm  
**7C/ST2** 40 x 30 x 60 mm  
**7C/ST2D** 40 x 50 x 100 mm

**Deko-Aufsteller Arctic für Ohrringe**  
Stand Arctic for earrings  
*Présentoir déco Arctic pour B.O.*

**DE3404A** 30 x 30 x 50 mm  
**DE3405A** 30 x 30 x 30 mm

**Deko-Sockel Arctic mit Loch, zzgl. Halter**  
Deco Plinth Arctic with hole, excl. ring holder  
*Socle déco Arctic avec perforation, support bague à commander séparément*

**S8/60S** 30 x 30 x 60 mm  
**S8/80S** 30 x 30 x 80 mm  
**S8/50S** 30 x 30 x 50 mm

**Deko-Sockel Arctic mit Loch, zzgl. Halter**  
Deco Plinth Arctic with hole, excl. ring holder  
*Socle déco Arctic avec perforation, support bague à commander séparément*

**S3/30S** H/∅: 30 x 25 mm  
**S3/40S** H/∅: 40 x 25 mm  
**S3/60S** H/∅: 60 x 25 mm

**Deko-Büste Arctic mit Kettenhalter (Gummi)**  
Decoration bust Arctic with chain support (elastic) behind  
*Buste déco Arctic avec fixe chaîne*

**7C/BU1AA** 160 x 130 x 120 mm  
**7C/BU1BA** 180 x 150 x 140 mm  
**7C/BU1CA** 170 x 180 x 170 mm

**Deko-Büste Arctic mit Kettenhalter (Gummi)**  
Decoration bust Arctic with chain support (elastic) behind  
*Buste déco Arctic avec fixe chaîne*

**7C/BU2BH** 170 x 90 x 210 mm  
**7C/BU2AH** 130 x 70 x 150 mm

**Deko-Büste Arctic für 5 Colliers**  
Decoration bust Arctic for 5 necklaces  
*Buste déco Arctic pour 5 colliers*

**7C/BU3** 220 x 85 x 250 mm

**Deko-Aufsteller Arctic für Ringe (Kegelform)**  
Stand Arctic for rings (cone shaped)  
*Présentoir déco Arctic pour bague (en forme de cône)*

**7C/R2** H/∅ 56 x 35 mm

**Deko-Aufsteller Arctic für Einzelring**  
Decoration stand Arctic, for 1 ring  
*Support déco Arctic pour bague*

**6RH/1C** ∅ 35 mm

**Armbandwelle Arctic mit 2 Gummis**  
Bracelet "wave" Arctic with 2 elastics  
*Support bracelet Arctic avec 2 élastiques*

**DP9A2** 166 x 30 x 47 mm  
**DP10A2** 170 x 18 x 50 mm

**Armbandwelle Arctic ohne Gummis**  
Bracelet "wave" Arctic without elastics  
*Support bracelet Arctic sans élastiques*

**7C/A1** L/B/H: 215 x 35 x 62 mm

**Welle Arctic für Collier oder Armband**  
"Wave" Arctic for bracelet or necklace  
*Vague Arctic pour collier ou bracelet*

**DPW1** 202 x 171 x 32 mm

**Ringhalter siehe Seite 24**  
Ringholder on page 24  
*Support bague page 24*

**Deko-Aufsteller Arctic für Ohrringe**  
Stand Arctic for earrings  
*Présentoir déco Arctic pour B.O.*

**DP23A** 40 x 60 mm  
**DP23** 40 x 45 mm

**Deko-Aufsteller Arctic für Ohrringe**  
Stand Arctic for earrings  
*Présentoir déco Arctic pour B.O.*

**7C/O1** 93 x 38 x 95 mm

Zubehör | Accessories | Accessoires

SERIE GRACE & ARCTIC



FROM STOCK

MADE OF PLASTIC

FOR SERIES GRACE & ARCTIC



**Ringhalter (neigbar) mit Stift**  
Poly clip (flexible) with peg  
*Support bague (souple)*

**KG50** Ø: 23 mm  
**KG50K** Ø: 19 mm  
**KG50/10** Ø: 23 mm



**Halter für Ohringe mit Stift**  
Earring tree with peg  
*Poutrelles en T pour B.O. avec pointe*

**KG51/25** 51 x 25 mm  
**KG51/35** 51 x 35 mm



**Kunststoffspange 10 mm breit, hoch**  
Transparent plastic C-Clip  
10 mm in width, vertical  
*Support plastique "POLY transparent" épaisseur 10 mm, vertical*

**7G/P1A** Ø: 69 mm  
**7G/P1B** Ø: 75 mm  
**7G/P1C** Ø: 83 mm



**Kunststoffspange 10mm breit, quer**  
Transparent plastic C-Clip  
10 mm in width, horizontal  
*Support plastique "POLY transparent" épaisseur 10mm, transversal*

**7G/P2A** Ø 73 mm/45°  
**7G/P2B** Ø 79 mm/45°

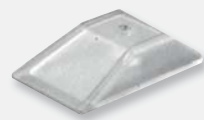

**Plexi-Sockel, (zzgl. Spangen / Zubehör, keine Einsteckhülse notwendig), lieferbar in transparent**  
Plinth, acrylic (plus C-Clips / accessories: peg-in barrel not necessary), available in transparent  
*Socle. Matière: Plexi (plus support / accessoires, des oeillets ne sont pas nécessaires) Livrable en transparent*

**7G/S11** 40 x 65 x 15 mm



**Verlängerung, Satiné**  
Extension, satin  
*Extension, satinée*

**7G/V1** 32 mm  
**7G/V2** 53 mm



**Acryl-Kissenhalter**  
Acrylic cushion holder  
*Support de coussinet acrylique*

**21772** 50 x 31 x 32 mm



**Beispiel**  
example  
*exemple*

# ETUI-SERIEN

BOX SERIES | SÉRIE ÉCRINS

Trend

26 - 27

Elegance

28 - 29

Twist

30 - 31

Style

32 - 33

Passion

34 - 35



PURE WHITE

SOFT

CARDBOARD BOX

FROM STOCK

Maßangaben: Länge x Breite x Höhe | Dimensions: Length x Width x Height | Dimensions: Longueur x Largeur x Hauteur



**Collier-Etui Trend**  
Necklace box Trend  
*Ecrin Trend pour collier*

**MD/V20C** 200 x 200 x 40 mm



**Uhren/Armband-Etui Trend**  
Watch/bracelet box Trend  
*Ecrin/bracelet Trend pour montre*

**MD/V20U** 110 x 110 x 80 mm



**Universal-Etui Trend**  
Universal box Trend  
*Ecrin Trend universel*

**MD/V20O** 60 x 60 x 40 mm  
**MD/V20OG** 80 x 80 x 40 mm



**Trauring-Etui Trend**  
Wedding ring box Trend  
*Ecrin Trend pour alliance*

**MD/V20TR** 80 x 50 x 40 mm



**Ring-Etui Trend**  
Ring box Trend  
*Ecrin Trend pour bague*

**MD/V20R** 60 x 60 x 40 mm

## SERIE TREND

Pure White mit einer dezent abgestepften Naht auf der Oberseite – das ist der Stil dieser hochwertig verarbeiteten Etuis. Das handweiche Kunstleder als Außenbezug und der fest schließende Deckel mit Klappscharnier lassen keine Fragen aufkommen – hier wurde nichts weggelassen. Jedes Etui kommt in einer stabilen Stülpkarton-Box als Umverpackung. Etuis und Umverpackungen können auf Wunsch individuell bedruckt werden.

Pure White with a subtle stitched seam on the top for detail - the styling of these finely crafted boxes is exactly on Trend. The soft touch leatherette as an outer cover and the securely closing hinged lid leaves nothing omitted. Each box comes packed in a sturdy cardboard outer box. Both box and outer packaging can be printed with your branding, individually on request.

*D'un blanc pur, avec une couture déceimment contrastée sur la partie supérieure - tel est le style de ces écrins aux finitions haut de gamme. Le cuir synthétique souple du revêtement extérieur et le couvercle hermétique avec une charnière à rabat répondent à toutes les attentes - rien n'a été laissé au hasard. Chaque écrin est reconditionné dans un suremballage solide en carton pliant. Il est possible d'apposer votre logo sur les écrins et leurs suremballages.*

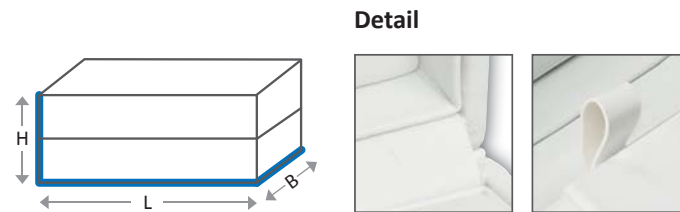

Druckbeispiel / print example / exemple d'impression

DRUCK AUF ANFRAGE

PRINT ON REQUEST  
IMPRESSION SUR DEMANDE



HIGH-GLOSS EXTERIOR

SUEDE INTERIOR

FROM STOCK

Maßangaben: Länge x Breite x Höhe | Dimensions: Length x Width x Height | Dimensions: Longueur x Largeur x Hauteur



**Collier-Etui Elegance**  
Necklace box Elegance  
*Ecrin Elegance pour collier*

**MD/V22C**  
200 x 200 x 40 mm



**Uhren/Armband-Etui Elegance**  
Watch/ bracelet box Elegance  
*Ecrin/ bracelet Elegance pour montre*

**MD/V22U**  
110 x 110 x 80 mm



**Universal-Etui Elegance**  
Universal box Elegance  
*Ecrin Elegance universel*

**MD/V22AN**  
60 x 60 x 35 mm

**MD/V22UN**  
80 x 80 x 35 mm



**Ring-Etui Elegance**  
Ring box Elegance  
*Ecrin Elegance pour bague*

**MD/V22R**  
60 x 60 x 40 mm

## SERIE ELEGANCE

Noch edler geht es nicht! Große Namen waren die Vorbilder für dieses besondere Piano-Finish. Eine Oberfläche, die Luxus bedeutet - schwarz und hochglänzend, das ist das Geheimnis der Etui-Serie Elegance. In Kombination mit dem tiefschwarzen Velour der Innenausstattung wird jedes Schmuckstück zum Unikat. Jedes Etui kommt in einer stabilen Stülpkarton-Box als Umverpackung. Etuis und Umverpackungen können auf Wunsch individuell bedruckt werden.

It doesn't get more elegant than this! Luxury was the brief for this particular box series. Black and high-gloss finish... In combination with the ebony black suede interior, the Elegance box series takes each piece of jewellery to another level. Each box is securely packed in a sturdy cardboard outer box. Both box and outer packaging can be printed individually on request.

*Il n'est pas possible d'être plus élégant! De grands noms ont servi de modèles à ce finish piano particulier. Une surface, qui est synonyme de luxe - noire et ultra-brillante, tel est le secret de la série d'écrins Elegance. Combinée à un velours d'un noir intense à l'intérieur, chaque bijou devient une pièce unique. Chaque écrin est reconditionné dans un suremballage solide en carton pliant. Il est possible d'apposer votre logo sur les écrins et leurs emballages.*

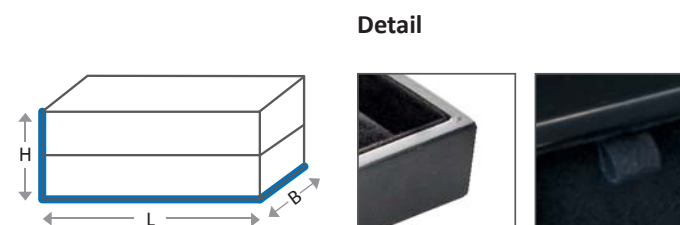

Druckbeispiel / print example / exemple d'impression

DRUCK AUF ANFRAGE

PRINT ON REQUEST  
IMPRESSION SUR DEMANDE

BLACK & WHITE

MAGNET FASTENER

LUXURY FEEL

FROM STOCK



Maßangaben: Länge x Breite x Höhe | Dimensions: Length x Width x Height | Dimensions: Longueur x Largeur x Hauteur



**Uhren/Armband-Etui Twist**  
Watch/bracelet box Twist  
Ecrin/bracelet Twist pour montre

**MD/V21U**  
110 x 110 x 80 mm



**Universal-Etui Twist**  
Universal box Twist  
Ecrin Twist universel

**MD/V21O**  
60 x 60 x 35 mm

**MD/V21OG**  
80 x 80 x 35 mm



**Ring-Etui Twist**  
Ring box Twist  
Ecrin Twist pour bague

**MD/V21R**  
60 x 60 x 40 mm

## SERIE TWIST

Eine moderne Etui-Serie, die dank ihrer klaren Formensprache und der gekonnten Kombination von schwarzen und weißen Elementen stilsicher in die Welt der angesagten Schmuck-trends passt. Die hochwertige Verarbeitung, Strukturkarton als haptisch schönes Überzugsmaterial und der sichere Magnetverschluss sind wesentliche Merkmale der Serie Twist. Etuis und Umverpackungen können auf Wunsch individuell bedruckt werden.

A modern box series which is right on today's jewellery trend, thanks to the stylish forms and the contemporary combination of black and white elements. The high quality finishes and the secure magnetic box fastening are essential features of the Twist series. Both the box, as well as the outer packaging can be printed individually on request.

Une série d'écrins modernes qui, grâce à un langage pur des formes et à la combinaison savante d'éléments noirs et blancs, s'harmonise avec style à l'univers des tendances actuelles de bijoux. Les finitions de qualité, la gainerie, le toucher agréable et le système fiable de fermeture aimantée sont des caractéristiques essentielles de la série „Twist“. Il est possible d'apposer votre logo sur les écrins et leurs suremballages.

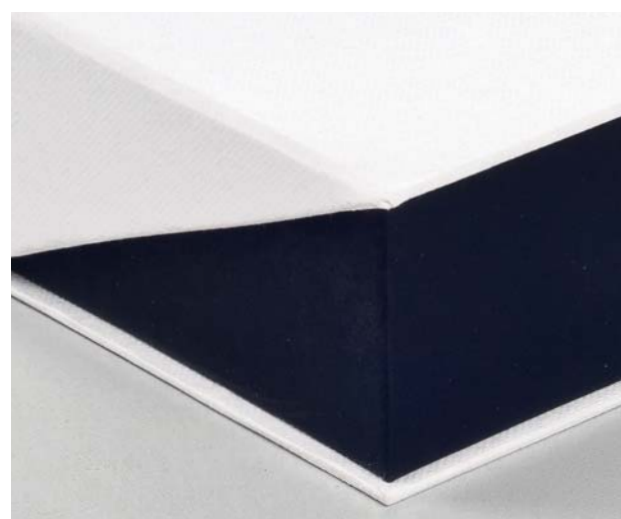
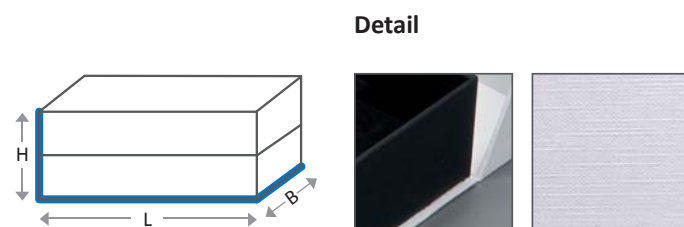

Druckbeispiel / print example / exemple d'impression

DRUCK AUF ANFRAGE

PRINT ON REQUEST  
IMPRESSION SUR DEMANDE





SILK RIBBON

IN BLACK OR WHITE

SOFT TOUCH

FROM STOCK

Maßangaben: Länge x Breite x Höhe | Dimensions: Length x Width x Height | Dimensions: Longueur x Largeur x Hauteur

**Collier-Etui Style**  
Necklace box Style  
*Ecrin Style pour collier*

**MD/V23C**  
200 x 200 x 40 mm

**Uhren-Etui Style**  
Watch box Style  
*Ecrin Style pour montre*

**MD/V23U**  
110 x 110 x 80 mm

**Ring-Etui Style**  
Ring box Style  
*Ecrin Style pour bague*

**MD/V23R**  
60 x 60 x 40 mm

**Universal-Etui Style**  
Universal box Style  
*Ecrin Style universel*

**MD/V23O**  
60 x 60 x 40 mm

**MD/V23OG**  
80 x 80 x 40 mm

## SERIE STYLE

Die praktische Etui-Serie - günstig aber nicht gewöhnlich. Das kleine Seidenband macht den Unterschied! Nicht nur als farbliches Accessoire, sondern auch als praktischer Griff zum Öffnen der Boxen, ist dieses Detail der Höhepunkt der weißen und schwarzen Etuis der Serie Style. Die Oberfläche ist mit Softtouch-Papier überzogen. Etuis und Umverpackungen können auf Wunsch individuell bedruckt werden und sind ab Lager lieferbar.

A practical box series, while inexpensive, is elevated to higher levels with the inclusion of a small silk ribbon. Not only an elegant feature, the silk ribbon acts as a practical tab for opening the Style boxes. The series is covered in luxurious Soft Touch paper and is available in white or black. Both the box as well as the outer packaging can be printed on request individually and the Style series is readily available from stock.

La série d'écrins, pratique, abordable et originale. Le petit ruban de soie fait la différence! Ce détail est le point-phare des écrins blancs et noirs de la série „Style“, pas uniquement en tant qu'accessoire coloré mais également en tant que „poignée“ pratique pour ouvrir les écrins. La surface en papier soft touch donne aux écrins un effet haut de gamme. Il est possible d'apposer votre logo sur les écrins et leurs suremballages, qui sont disponibles en stock.

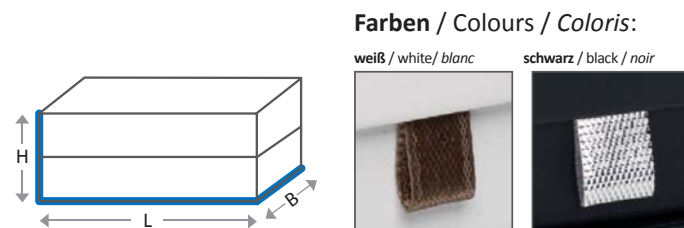

Druckbeispiel / print example / exemple d'impression

DRUCK AUF ANFRAGE

PRINT ON REQUEST  
IMPRESSION SUR DEMANDE



Maßangaben: Länge x Breite x Höhe | Dimensions: Length x Width x Height | Dimensions: Longueur x Largeur x Hauteur



**Uhren/Armband-Etui Passion**  
Watch/bracelet box Passion  
*Ecrin/bracelet Passion pour montre*

**MD/V24U**  
110 x 110 x 80 mm



**Universal-Etui Passion**  
Universal box Passion  
*Ecrin Passion universel*

**MD/V24O**  
60 x 60 x 40 mm

**MD/V24OG**  
80 x 80 x 40 mm



**Ring-Etui Passion**  
Ring box Passion  
*Ecrin Passion pour bague*

**MD/V24R**  
60 x 60 x 40 mm

## SERIE PASSION

Eine außergewöhnliche Etui-Serie, stilsicher und hochwertig. Mit Passion treffen Sie bei Ihrer anspruchsvollen Kundschaft ins Schwarze. Bei diesen Etuis ist nichts dem Zufall überlassen - Design, Material und Verarbeitung sind detailliert ausgearbeitet und perfekt umgesetzt. Jedes Etui kommt in einer stabilen Stülpkarton-Box als Umverpackung. Etuis und Umverpackungen können auf Wunsch individuell bedruckt werden. Die Etuis der Serie Passion sind in den Farbkombinationen Schwarz/Rot und Weiß/Rot ab Lager lieferbar.

An exceptional box series for those passionate about style and sophistication. Flawless design, high quality materials and exacting workmanship are perfectly executed in the Passion series which is available from stock in the colour combinations of either Black with Red or White with Red. Each box comes with a sturdy cardboard outer box. Both box and outer packaging can be printed on request individually.

Une série d'écrins, exceptionnelle, stylée et haut de gamme. Avec Passion, vous répondez aux attentes de votre clientèle exigeante. Avec ces écrins, rien n'est laissé au hasard - design, matériau, finition, tout est travaillé dans le détail et réalisé à la perfection. Chaque écrin est reconditionné dans un suremballage solide en carton pliant. Il est possible d'apposer votre logo sur les écrins et leurs suremballages. Les écrins de la série „Passion“ sont disponibles en stock dans les combinaisons de couleur noir/rouge et blanc/rouge.

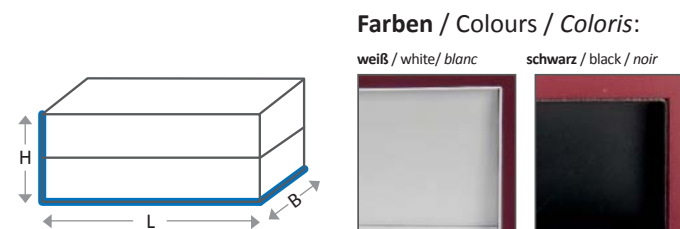

Druckbeispiel / print example / exemple d'impression

DRUCK AUF ANFRAGE

PRINT ON REQUEST  
IMPRESSION SUR DEMANDE

# LADEN-SERIEN

TRAY SERIES | SÉRIE PLATEAUX

Rebra Extralight

37 - 55

Vario Norm

56 - 78

Vario Style

79 - 80

Vario Lux

81 - 93

Basic Plus

94 - 104



ITEMS IN STOCK

LIGHTEST TRAY SERIES

TRAYS IN  
BLUE, GREY & BLACK

PADS IN DOMY WHITE  
& BLACK

1 TRAY SIZE

## SERIE REBRA EXTRALIGHT

Das patentierte Rebra Extralightsystem ist eines der weltweit leichtesten Präsentationssysteme für Uhren, Schmuck und Schreibgeräte. Mit Leichtigkeit entlasten Sie Ihr Rückgrat und sparen bei Reisen teure Übergepäckzuschläge. Rebra Extralight bietet Ihnen die ganze Vielfalt verkaufsfördernder Präsentation und wiegt bis zur Hälfte weniger als herkömmliche Präsentationsladen - ohne dabei an Komfort einzubüßen.

The patented Rebra Extralight system is one of the lightest systems in the world for presenting watches, jewellery and writing implements. The system offers you several different ways to display your products to their very best, effectively promoting sales, whilst weighing up to 50% less than conventional presentation trays. Maximum sales, less back strain, less excess baggage charges whilst travelling... without compromising on quality or convenience.

*Le système breveté Rebra Extralight est l'un des systèmes de présentation de montres, de bijoux et de stylos les plus légers au monde. Ce système soulage votre dos et vous évite d'importants suppléments de bagages lors de vos déplacements. Jusqu'à deux fois plus léger que les mallettes de présentation traditionnelles, Rebra Extralight vous offre une grande variété de présentations promotionnelles et un confort toujours optimal.*

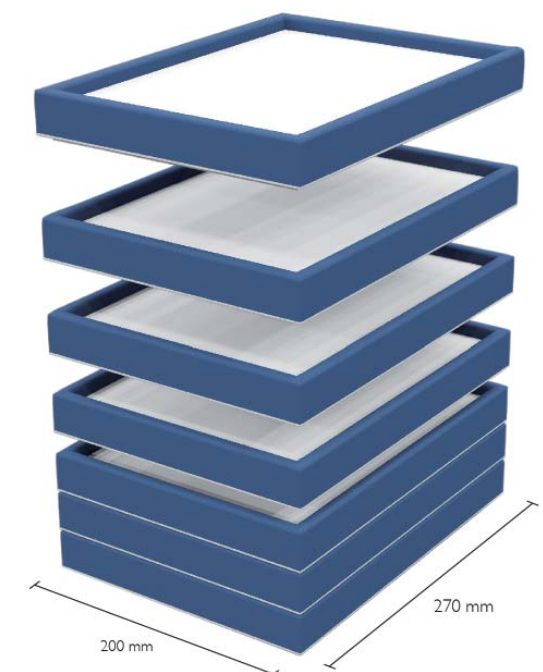

Maßangaben: Länge x Breite x Höhe | Dimensions: Length x Width x Height | Dimensions: Longueur x Largeur x Hauteur



**Leerlade, 1 Fach 250 x 180 mm, Bodenunterseite hochgesetzt**  
Empty tray with 1 compartment 250 x 180 mm, with recessed back, stackable  
*Plateau vide, 1 compartiment 250 x 180 mm, avec dos creusé, empilable*

<b>RL1F/17</b>	270 x 200 x 17 mm	98g
<b>RL1F/27</b>	270 x 200 x 27 mm	118g
<b>RL1F/33</b>	270 x 200 x 33 mm	134g
<b>RL1F/48</b>	270 x 200 x 48 mm	138g



**3 Fächer, Fachmaß: 250 x 60 mm, Bodenunterseite hochgesetzt**  
3 compartments, size: 250 x 60 mm, with recessed back, stackable  
*3 compartiments, dimension: 250 x 60 mm, avec dos creusé, empilable*

<b>RL3F/17</b>	270 x 200 x 17 mm	119g
----------------	-------------------	------

**Polster für Lade RL3F**  
Pad for tray RL3F  
*Coussinet pour plateau RL3F*

<b>RS3</b>	250 x 60 mm	
------------	-------------	--



**16 Fächer, Fachmaß: 62 x 45 mm, Bodenunterseite hochgesetzt**  
16 compartments, size: 62 x 45 mm, with recessed back, stackable  
*16 compartiments, dimension: 62 x 45 mm, avec dos creusé, empilable*

<b>RL16F/17</b>	270 x 200 x 17 mm	106g
<b>RL16F/27</b>	270 x 200 x 27 mm	144g



**20 Fächer, Fachmaß: 62 x 35 mm, Bodenunterseite hochgesetzt**  
20 compartments, size: 62 x 35 mm, with recessed back, stackable  
*20 compartiments, dimension 62 x 35 mm, avec dos creusé, empilable*

<b>RL20F/17</b>	270 x 200 x 17 mm	106g
-----------------	-------------------	------



**Polster für Leerlade der Serie: RL1F**  
Pad for empty tray series: RL1F  
*Carte pour plateau de la série: RL1F*

<b>RS1</b>	250 x 180 mm	
------------	--------------	--



**7 Fächer, Fachmaß: 220 x 24 mm, Bodenunterseite hochgesetzt**  
7 compartments, size: 220 x 24 mm for pads: RS7, with recessed back, stackable  
*7 compartiments, dimension: 220 x 24 mm, avec dos creusé, empilable*

<b>RL7F/17</b>	270 x 200 x 17 mm	117g
----------------	-------------------	------

**Polster für Lade RL7F**  
Pad for tray RL7F  
*Coussinet pour plateau RL7F*

<b>RS7A2</b>	220 x 24 mm	
--------------	-------------	--



**RS16** 62 x 45 mm

**Polster, flach**  
Pad, flat  
*Coussinet, plat*



**RS16A4** 45 x 62 mm

**Polster für Manschettenknöpfe**  
Cufflinks Pad  
*Coussinet pour boutons de manchettes*



**RS20** 62 x 35 mm

**Polster, flach**  
Pad, flat  
*Coussinet, plat*



**Polster für Leerlade der Serie: RL1F, 27 Haken 784/1 (gold- oder silberfarben)**  
Pad for empty tray series RL1F, 27 hooks 784/1 (gilt or chrome)  
*Carte pour plateau de la série: RL1F, 27 crochets 784/1 (dorés ou chromés)*

<b>RS1/27W</b>	250 x 180 mm	silberf.
<b>RS1/27G</b>	250 x 180 mm	goldf.



**9 Fächer, Fachmaß: 83 x 60 mm, Bodenunterseite hochgesetzt**  
9 compartments, size: 83 x 60 mm, with recessed back, stackable  
*9 compartiments, dimension: 83 x 60 mm, avec dos creusé, empilable*

<b>RL9F/17</b>	270 x 200 x 17 mm	110g
<b>RL9F/27</b>	270 x 200 x 27 mm	144g



**RS16HA2** 62 x 45 mm

**Polster für Anhänger mit Haken Nr. 530/8,5 (gold- oder silberfarben)**  
Pendant Pad, hook no. 530/8,5 (gilt or chrome)  
*Coussinet pour pendentif, crochet no. 530/8,5 (dorés ou chromés)*



**RS20HA2** 62 x 35 mm

**Polster für Anhänger mit Haken Nr. 530/8,5 (gold- oder silberfarben)**  
Pendant pad, hook no. 530/8,5 (gilt or chrome)  
*Coussinet pour pendentif, crochet no. 530/8,5 (dorés ou chromés)*



**Polster für Leerlade der Serie: RL1F, 36 Haken 784/1 (gold- oder silberfarben)**  
Pad for empty tray series RL1F, 36 hooks 784/1 (gilt or chrome)  
*Carte pour plateau de la série: RL1F, 36 crochets 784/1 (dorés ou chromés)*

<b>RS1/36W</b>	250 x 180 mm	silberf.
<b>RS1/36G</b>	250 x 180 mm	goldf.



**RS9** 83 x 60 mm

**Polster, flach**  
Pad, flat  
*Coussinet, plat*



**RS9V** 83 x 60 mm

**erhöhtes Polster für Ohringe**  
Earring pad  
*Coussinet boucles B.O.*



**RS16HA9** 62 x 45 mm

**Polster für Anhänger mit Haken Nr. 765 (gold- oder silberfarben)**  
Pendant Pad, hook no. 765 (gilt or chrome)  
*Coussinet pour pendentif, crochet no. 765 (dorés ou chromés)*



**RS20HA9** 62 x 35 mm

**für Anhänger mit Haken Nr. 765 (gold- oder silberfarben)**  
Pendant pad, hook no. 765 (gilt or chrome)  
*Coussinet pour pendentif, crochet no. 765 (dorés ou chromés)*



**Garnitur-Polster für Leerlade, Serie: RL1F. 2 pro Lade**  
Pad for empty tray of the series RL1F. 2 per tray  
*Carte pour plateau série: RL1F. 2 par plateau*

<b>RS1GA</b>	180 x 125 mm	
--------------	--------------	--



**RS9HA2** 83 x 60 mm

**Polster für Anhänger mit Haken Nr. 530/8,5 (gold- oder silberfarben)**  
Pad for pendant, hook no. 530/8,5 (gilt or chrome)  
*Coussinet pour pendentif, crochet no. 530/8,5 (dorés ou chromés)*



**RS16R** 62 x 45 mm

**erhöhtes Polster für 1 Ring**  
raised pad for 1 ring  
*Coussinet pour 1 bague*



**RS20V/Q** 35 x 62 mm

**erhöhtes Polster für Ohringe, quer**  
Earrings pad, landscape  
*Coussinet pour B.O., horizontal*



**Polster mit Tambour, für Leerlade der Serie: RL1F. 2 pro Lade**  
Pad with neckform for plain tray: RL1F. 2 per tray  
*Carte avec tambour pour plateau vide de la série RL1F. 2 par plateau*

<b>RS2TA</b>	250 x 90 mm	
--------------	-------------	--



**RS9/WiH** 83 x 60 mm

**Winkelkarte für Ohringe, hoch**  
Earring angle pad, portrait  
*Coussinet pour B.O., vertical*



**RS16V** 62 x 45 mm

**erhöhtes Polster für Ohringe, hoch**  
Raised pad for earrings, portrait  
*Coussinet pour B.O., vertical*



**RS16V/Q** 45 x 62 mm

**erhöhtes Polster für Ohringe, quer**  
Raised pad for earrings, landscape  
*Coussinet pour B.O., horizontal*



**RS9HA9** 83 x 60 mm

**Polster für Anhänger mit Haken Nr. 765 (gold- oder silberfarben)**  
Pad for pendant, hook no. 765 (gilt or chrome)  
*Coussinet pour pendentif, crochet no. 765 (dorés ou chromés)*



**RS16/WiH** 62 x 45 mm

**Winkelkarte für Ohringe, hoch**  
Earring angle pad, portrait  
*Coussinet pour B.O., vertical*



**RS16/WiQ** 45 x 62 mm

**Winkelkarte für Ohringe, quer**  
Earring angle pad, landscape  
*Coussinet pour B.O., horizontal*



**RS9V/WiQ** 60 x 83 mm

**Winkelkarte für Ohringe, quer**  
Earring angle pad, landscape  
*Coussinet pour B.O., horizontal*

Maßangaben: Länge x Breite x Höhe | Dimensions: Length x Width x Height | Dimensions: Longueur x Largeur x Hauteur



**25 Fächer, Fachmaß: 50 x 35 mm für Polster der Serie: RS25, Bodenunterseite hochgesetzt**  
 25 compartments, size: 50 x 35 mm for pads: RS25, with recessed back, stackable  
*25 compartiments, dimension 50 x 35 mm pour coussinets de la série: RS25, avec dos creusé, empilable*

**RL25F/17** 270 x 200 x 17 mm 106g



**30 Fächer, Fachmaß: 40 x 35 mm, Bodenunterseite hochgesetzt, für Polster der Serie RS30**  
 30 compartments, size: 40 x 35 mm for pads: RS30, with recessed back, stackable  
*30 compartiments, dimension 40 x 35 mm, avec dos creusé, empilable, pour coussinets de la série: RS30*

**RL30F/17** 270 x 200 x 17 mm 104g



**25 Fächer, Fachmaß: 50 x 35 mm für Polster der Serie: RS25, Bodenunterseite hochgesetzt**  
 25 compartments, size: 50 x 35 mm for pads: RS25, with recessed back, stackable  
*25 compartiments, dimension 50 x 35 mm pour coussinets de la série: RS25, avec dos creusé, empilable*

**RL25F/27** 270 x 200 x 27 mm 106g



**30 Fächer, Fachmaß: 40 x 35 mm, Bodenunterseite hochgesetzt, für Polster der Serie RS30**  
 30 compartments, size: 40 x 35 mm for pads: RS30, with recessed back, stackable  
*30 compartiments, dimension 40 x 35 mm, avec dos creusé, empilable, pour coussinets de la série: RS30*

**RL30F/27** 270 x 200 x 27 mm 104g



**RS25** 50 x 35 mm **Polster, glatt**  
 Pad, flat  
*Coussinet, lisse*



**RS30** 40 x 35 mm **Polster, glatt**  
 Pad, flat  
*Coussinet, lisse*

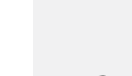

**RS25HA2** 50 x 35 mm **Polster für Anhänger mit Haken Nr. 530/8,5 (gold- oder silberfarben)**  
 Pendant pad, hook no. 530/8,5 (gilt or chrome)  
*Coussinet pour pendentif, crochet no. 530/8,5 (dorés ou chromés)*



**RS30HA2** 40 x 35 mm **Polster für Anhänger mit Haken Nr. 530/8,5 (gold- oder silberfarben)**  
 Pendant pad, hook no. 530/8,5 (gilt or chrome)  
*Coussinet pour pendentif, crochet no. 530/8,5 (dorés ou chromés)*



**RS25HA9** 50 x 35 mm **Polster für Anhänger mit Haken Nr. 765 (gold- oder silberfarben)**  
 Pendant pad, hook no. 765 (gilt or chrome)  
*Coussinet pour pendentif, crochet no. 765 (dorés ou chromés)*

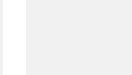

**RS30HA9** 40 x 35 mm **für Anhänger mit Haken Nr. 765 (gold- oder silberfarben)**  
 Pendant pad, hook no. 765 (gilt or chrome)  
*Coussinet pour pendentif, crochet no. 765 (dorés ou chromés)*



**RS25V** 50 x 35 mm **erhöhtes Polster für Ohringe, hoch**  
 Raised earrings pad, portrait  
*Coussinet pour B.O., vertical*



**RS30V** 40 x 35 mm **erhöhtes Polster für Ohringe**  
 Raised earrings pad  
*Coussinet pour B.O.*



**RS25V/Q** 35 x 50 mm **erhöhtes Polster für Ohringe, quer**  
 Raised earring pad, landscape  
*Coussinet pour B.O., horizontal*



**RS30/WiH** 40 x 35 mm **Winkelkarte für Ohringe, hoch**  
 Earring angle pad, portrait  
*Coussinet pour B.O., vertical*



**RS25/WiH** 50 x 35 mm **Winkelkarte für Ohringe, hoch**  
 Earring angle pad, portrait  
*Coussinet pour B.O., vertical*



**RS30/WiQ** 35 x 40 mm **Winkelkarte für Ohringe, quer**  
 Earring angle pad, landscape  
*Coussinet pour B.O., horizontal*



**RS25/WiQ** 35 x 50 mm **Winkelkarte für Ohringe, quer**  
 Earring angle pad, landscape  
*Coussinet pour B.O., horizontal*



**Büstenlade: Collier**  
 Necklace tray  
*Plateau pour collier*

**RL02/15** 270 x 200 x 15 mm 110g



**Büstenlade: Collier, Stecker**  
 Set tray: necklace/earrings  
*Plateau à parure: Collier, B.O.*

**RL02A/15** 270 x 200 x 15 mm 110g



**Büstenlade: Collier, Ring**  
 Set tray: necklace/ring  
*Plateau à parure: Collier/bague*

**RL03/15** 270 x 200 x 15 mm 110g



**Büstenlade: Collier, Ring, Stecker**  
 Set tray: necklace/ring/earrings  
*Plateau à parure: Collier, bague, B.O.*

**RL03A/15** 270 x 200 x 15 mm 110g



**Büstenlade: Collier/Band/Ring/Stecker**  
 Set tray: necklace/bracelet/ring/earrings  
*Plateau à parure: Coll./Bracelet/Bague/B.O.*

**RL01/15** 270 x 200 x 15 mm 110g



**Kettenlade mit 6 Schlaufen**  
 Chain tray with 6 loops  
*Plateau à 6 boucles*

**RLD4/1** 270 x 200 x 33 mm 213g



**Ketten- und Armbandlade (Hakenleiste: goldfarben)**  
 Chain and bracelet tray (strip of hooks: gilt)  
*Plateau pour chaînes et bracelets (crochets: dorés)*

**RL16G/18** 270 x 200 x 18 mm 110g



**Ketten- und Armbandlade (Hakenleiste: silberfarben)**  
 Chain and bracelet tray (strip of hooks: chrome)  
*Plateau pour chaînes et bracelets (crochets: chromés)*

**RL16W/18** 270 x 200 x 18 mm 110g



**Ketten- und Armbandlade mit 16 Haken (goldfarben), 16 Gummis**  
 Chain and bracelet tray, 16 hooks (strip of hooks: gilt), 16 elastics  
*Plateau pour chaînes et bracelets, 16 crochets (dorés), 16 élastiques*

**RL16GG18** 270 x 200 x 18 mm 110g



**Ketten- und Armbandlade mit 16 Haken (silberfarben), 16 Gummis**  
 Chain and bracelet tray, 16 hooks (strip of hooks: chrome), 16 elastics  
*Plateau pour chaînes et bracelets, 16 crochets (chromés), 16 élastiques*

**RL16WG18** 270 x 200 x 18 mm 110g

Maßangaben: Länge x Breite x Höhe | Dimensions: Length x Width x Height | Dimensions: Longueur x Largeur x Hauteur



**Ketten- und Armbandlade mit 16 Haken (goldfarben), 16 Gummis + Polytasche**  
Chain and bracelet tray. 16 hooks (strip of hooks: gilt), 16 elastics + poly pocket.  
*Plateau pour chaînes et bracelets. 16 crochets (dorés), 16 élastiques + poche en poly.*

**RL16GT18** 270 x 200 x 18 mm 110g



**Ketten- und Armbandlade mit 16 Haken (silberfarben), 16 Gummis + Polytasche**  
Chain and bracelet tray. 16 hooks (strip of hooks: chrome), 16 elastics + poly pocket.  
*Plateau pour chaînes et bracelets. 16 crochets (chromés), 16 élastiques + poche en poly.*

**RL16WT18** 270 x 200 x 18 mm 110g



**Ringlade, 3 x 4 Einzelbäckchen (für breite Ringe). Bodenunterseite hochgesetzt**  
Tray for 12 wide rings. With recessed back, stackable  
*Plateau pour 12 bagues avec corps large. Avec dos creusé, empilable*

**RL12RZ** 270 x 200 x 33 mm 218g



**Ringlade, 3 x 5 Einzelbäckchen (für breite Ringe). Bodenunterseite hochgesetzt**  
Tray for 15 wide rings. With recessed back, stackable  
*Plateau pour 15 bagues avec corps large. Avec dos creusé, empilable*

**RL15RZ** 270 x 200 x 33 mm 238g



Laden für Ringe | Trays for rings | Plateaux pour bagues

REBRA



**Ringlade, 3 x 5 Einzelbäckchen (für Trauringe). Bodenunterseite hochgesetzt**  
Tray for 15 x 2 rings (wedding bands). With recessed back, stackable  
*Plateau muni de 3 x 5 cases à doubles fentes pour alliances. Avec dos creusé, empilable*

**RL15TR** 270 x 200 x 33 mm 258g



**Ringlade, 4 x 6 Einzelbäckchen (für breite Ringe). Bodenunterseite hochgesetzt**  
Tray for 24 wide rings. With recessed back, stackable  
*Plateau pour 24 bagues avec corps large. Avec dos creusé, empilable*

**RL24RZ** 270 x 200 x 33 mm



**Ringlade für 28 Ringe bis 3 mm Ringschiene. Ringhöhe: 21 mm**  
Ring tray for 28 rings. Takes rings up to 3 mm in width and 21 mm in height  
*Plateau à 28 bagues, largeur corps de bague jusqu'à 3 mm, hauteur de bague jusqu'à 21 mm*

**RL28RA21** 270 x 200 x 21 mm



**Ringlade, 4 x 6 Einzelbäckchen für Trauringe. Bodenunterseite hochgesetzt**  
Tray for 24 x 2 rings (wedding bands). With recessed back, stackable  
*Plateau muni de 4 x 6 cases à doubles fentes pour alliances. Avec dos creusé, empilable*

**RL24TR** 270 x 200 x 33 mm



**Ringlade + 4 Polster der Serie RE4, Ringhöhe: 35 mm, vertiefte Rückseite**  
Ring tray + 4 pads RE4, height of ring: 35 mm, recessed back  
*Plateau à 4 coussinets de la série RE4, hauteur de bague jusqu'à 35 mm, dos creusé*

**RL4RF/22** 270 x 200 x 22 mm 100g



**Ringlade, mit 8 herausnehmbaren Rollen. Bodenunterseite hochgesetzt**  
Ring tray, with 8 removable rolls, with recessed back, stackable  
*Plateau bagues avec 8 rouleaux amovibles. Avec dos creusé, empilable*

**RL8W/33** 270 x 200 x 33 mm 215g



**Ringlade für 28 Ringe bis 5 mm Ringschiene. Ringhöhe: 21 mm**  
Ring tray for 28 rings. Takes rings up to 5 mm in width and 21 mm in height  
*Plateau à 28 bagues, largeur corps de bague jusqu'à 5 mm, hauteur de bague jusqu'à 21 mm*

**RL28R/21** 270 x 200 x 21 mm 85g



**Ringlade, 4 x 6 Einzelbäckchen, Bodenunterseite hochgesetzt**  
Tray for 24 rings. With recessed back, stackable  
*Plateau pour 24 bagues. Avec dos creusé, empilable*

**RL24R** 270 x 200 x 33 mm



**RE4**  
flaches Polster  
Flat pad  
*Coussinet plat*



**RE4/5**  
5er-Ringeinsatz  
Insert for 5 rings  
*Coussinet à 5 fentes bagues*

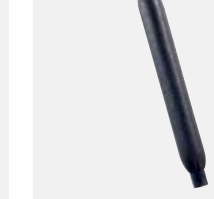

**RL8WL**  
Ersatzrolle  
Spare ring rolls  
*Rouleaux bagues en vrac*



**RE4/4KL**  
Polster mit 4 POLY-Zungen  
Pad with 4 poly clips  
*Coussinet à 4 languettes poly*



**RE4/5KL**  
Polster mit 5 POLY-Zungen  
Pad with 5 poly clips  
*Coussinet à 5 languettes poly*



**Ringlade für 8 x 3 Ringe (Triset). Bodenunterseite hochgesetzt**  
Ring tray for 8 x 3 rings (tri sets). With recessed back, stackable  
*Plateau pour 8 x 3 bagues (trisets). Avec dos creusé, empilable*

**RL8Tri** 270 x 200 x 33 mm 217g



**Lade mit 21-H-Schlitzschachbrettartig angeordnet (2-farbig abgesetzt), stapelbar**  
Ring tray for 21 rings, stackable  
*Plateau bagues à 21 fentes en quinconce, empilable*

**RL21RA27** 270 x 200 x 27 mm



**RE4/6KL**  
Polster mit 6 POLY-Zungen  
Pad with 6 poly clips  
*Coussinet à 6 languettes poly*



**Ringlade mit 9 Wulsten, 8 Ringreihen Bodenunterseite hochgesetzt**  
Ring tray with 9 rolls. With recessed back, stackable  
*Plateau bagues avec 9 rouleaux. Avec dos creusé, empilable*

**RL9W/33** 270 x 200 x 33 mm 280g

Maßangaben: Länge x Breite x Höhe | Dimensions: Length x Width x Height | Dimensions: Longueur x Largeur x Hauteur



Laden für Uhren & Armreife | Trays for watches & bracelets | Plateaux pour montres & bracelets rigides

REBRA



**Lade, 4 Fächer ca. 240 x 42 mm, Bodenunterseite hochgesetzt, stapelbar**  
Tray, 4 compartments approx. 240 x 42 mm, with recessed back, stackable  
*Plateau, 4 compartiments env. 240 x 42 mm, avec dos creusé, empilable*

**RL4T/18** 270 x 200 x 18 mm 100g



**Lade, 6 Fächer ca. 240 x 28 mm, Bodenunterseite hochgesetzt, stapelbar**  
Tray, 6 compartments approx. 240 x 28 mm, with recessed back, stackable  
*Plateau, 6 compartiments env. 240 x 28 mm avec dos creusé, empilable*

**RL6T/18** 270 x 200 x 18 mm 100g



**Lade, 5 Fächer ca. 240 x 33 mm, Bodenunterseite hochgesetzt, stapelbar**  
Tray, 5 compartments approx. 240 x 33 mm, with recessed back, stackable  
*Plateau, 5 compartiments env. 240 x 33 mm avec dos creusé, empilable*

**RL5T/18** 270 x 200 x 18 mm 100g



**Lade, 10 Fächer ca. 23 x 170 mm, Bodenunterseite hochgesetzt, stapelbar**  
Tray, 10 compartments approx. 23 x 170 mm, with recessed back, stackable  
*Plateau, 10 compartiments env. 23 x 170 mm avec dos creusé, empilable*

**RL10T/18** 270 x 200 x 18 mm 100g



**Lade, 2 gefederte Klappen, gewölbt, Bodenunterseite hochgesetzt**  
Tray, domed, with 2 elasticated flaps top and bottom, with recessed back, stackable  
*Plateau bombé, 2 rabats à élastiques, avec dos creusé, empilable*

**RLD3** 270 x 200 x 33 mm 263g



**Lade mit 2 x 4 Gummis für 4 Uhren, Bodenunterseite hochgesetzt**  
Tray with 2 x 4 elastics for 4 watches, with recessed back, stackable  
*Plateau à 2 x 4 élastiques pour 4 montres, avec dos creusé, empilable*

**RL4U/18** 270 x 200 x 18 mm 103g



**Lade mit 2 x 5 Gummis für 5 Uhren, Bodenunterseite hochgesetzt**  
Tray with 2 x 5 elastics for 5 watches, with recessed back, stackable  
*Plateau à 2 x 5 élastiques pour 5 montres, avec dos creusé, empilable*

**RL5U/18** 270 x 200 x 18 mm 103g



**Lade mit 2 x 6 Gummis für 6 Uhren, Bodenunterseite hochgesetzt**  
Tray with 2 x 6 elastics for 6 watches, with recessed back, stackable  
*Plateau à 2 x 6 élastiques pour 6 montres, avec dos creusé, empilable*

**RL6U/18** 270 x 200 x 18 mm 103g



**Lade für 8 breite Uhren inklusive Spangen SP11, Bodenunterseite hochgesetzt**  
Watch tray with 8 supports (SP11), with recessed back, stackable  
*Plateau pour montres à 8 supports montres (SP11), avec dos creusé, empilable*

**RL8U/48** 270 x 200 x 48 mm 100g



**Lade für 10 Uhren, inklusive 10 Spangen SP11, Bodenunterseite hochgesetzt**  
Watch tray with 10 supports SP11, with recessed back, stackable  
*Plateau pour montres à 10 supports montres SP11, avec dos creusé, empilable*

**RL10U/48** 270 x 200 x 48 mm 100g



**Uhrspange, transparent**  
Transparent watch support  
*Support montre transparent*

**SP11**



**2-tlg. Armreiflade, Bodenunterseite hochgesetzt**  
Bangle tray, 2 parts, with recessed back, stackable  
*Plateau en 2 parties pour bracelets rigides, avec dos creusé, empilable*

**RL30/90** 270 x 200 x 90 mm 320g



**Abstandspolster**  
Divider pads  
*Coussinets d'espacement*

**RL30Z**



**2-tlg. Armreiflade (mit 3 x 9 Wulsten), Bodenunterseite hochgesetzt**  
Bangle tray, 2 parts, with 3 x 9 rolls, with recessed back, stackable  
*Plateau en 2 parties pour bracelets rigides avec 3 x 9 rouleaux, avec dos creusé, empilable*

**RL31/90** 270 x 200 x 90 mm 400g



**Lade mit 2 x 10 Gummis für Kugelschreiber, Bodenunterseite hochgesetzt**  
Tray with 2 x 10 elastics for 10 pens, with recessed back, stackable  
*Plateau à 2 x 10 élastiques pour 10 stylos à bille, avec dos creusé, empilable*

**RL18/18** 270 x 200 x 18 mm 103g



**Zwischenrahmen**  
Spacer  
*Cadre réhausseur*

**RLZ/17** 227 x 200 x 17 mm



**Zwischenrahmen**  
Spacer  
*Cadre réhausseur*

**RLZ/33** 227 x 200 x 33 mm

Maßangaben: Länge x Breite x Höhe | Dimensions: Length x Width x Height | Dimensions: Longueur x Largeur x Hauteur

Set-Laden | Set trays | Plateaux à parure

REBRA



zzgl. Polster  
excl. pads  
hors cartes



**Lade mit 2 x 3 vertikalen Polyfächern 52 x 35 mm und 3 Tri-Set Bäckchen, zzgl. Karten**  
Set tray with 2 x 3 deep poly compartments 52 x 25 mm portrait, and 3 ring containers for 3 x 3 rings, plus pads  
*Plateau à parure à 2 x 3 compartiments en poly surélevés 52 x 35 mm verticaux, et 3 cases de bagues „triset“, cartes à commander séparément*

**RLD33V** 270 x 200 x 33 mm



**Set-Lade für 2 x 3 Ringe (WA/R16), 2 x 3 Fächer für RS 25 Hochformat und 2 x 3 Fächer für RS30 Querformat, zzgl. Karten**  
Set tray with 2 x 3 rings ( R16) , 2 x 3 comp. RS30 (landscape), 2 x 3 comp. RS25 (portrait), plus pads  
*Plateau à parure avec 2 x: 3 compartiments RS30 horizontaux, 3 comp. RS25 verticaux et 3 fentes pour bagues, cartes à commander séparément*

**RLD22A** 270 x 200 x 33 mm



**Set-Lade, Platte 3 mm Schaum/Unterbau 6 mm. Links: 3 Ringschlitz (WA/R16). Mitte: 3 Klappen für Collier mit je 2 Einschnitten in jeder Klappe oben. Rechts: 3 Fächer für RS30 (Hochformat), zzgl. Karten**  
Set tray with 3 ring slots, 3 necklace flaps with resp. 2 slits on top and 3 compartments for RS30 (portrait), plus pads  
*Plateau à parure avec 3 fentes pour bagues, 3 rabats pour colliers avec resp. 2 fentes et 3 comp. RS30 verticaux, cartes à commander séparément*

**RLD11A** 270 x 200 x 33 mm



**Lade, Querformat mit 2 x 5 Polyfächern 52 x 35 mm vertieft, darunter 5 Ringbäckchen, zzgl. Karten**  
Set tray with 2 x 5 deep poly compartments 52 x 35 mm and 5 ring containers, plus pads  
*Plateau à parure à 2 x 5 compartiments en poly surélevés 52 x 35 mm et 5 cases de bagues, cartes à commander séparément*

**RLD35V** 270 x 200 x 33 mm



**Lade mit 2 x 2 Fächer, flach, 83 x 118 mm für Karten V118H**  
Set tray with 2 x 2 flat compartments 83 X 118 mm for pads V118H  
*Plateau à parure à 2 x 2 compartiments plat 83 x 118 mm pour cartes V118H*

**RL4TF/27** 270 x 200 x 27 mm  
**RL4TF/33** 270 x 200 x 33 mm



**Lade Querformat, mit 2 x 5 Polyfächern 52 x 35 mm, vertieft, darunter 5 Trauringbäckchen (Groß/Quadratisch), zzgl. Karten**  
Set tray with 2 x 5 deep poly compartments 52 X 35 mm and 5 big square ring containers for wedding bands, plus pads  
*Plateau à parure à 2 x 5 compartiments en poly surélevés 52 x 35 mm et 5 cases de bagues (grandes/ carrées) pour alliances, cartes à commander séparément*

**RLD35TR** 270 x 200 x 33 mm



**Abschlussdeckel flach**  
Top lid  
*Couvercle*

**RA1/16** 270 x 200 x 16 mm 78g



**Abschlussdeckel für Büstenladen RL02/15 und RL03/15 (Büste mittig)**  
Top lid for trays with raised neckform RL02/15 and RL03/15 (centered bust)  
*Couvercle pour plateau bustes RL02/15 et RL03/15 tambour au centre*

**RA1GM** 270 x 200 x 48 mm 140g



**Abschlussdeckel für Büstenladen RL01/15**  
Top lid for trays with raised neck RL01/15  
*Couvercle pour plateaux a parure largeur, RL01/15*

**RA1G/48** 270 x 200 x 48 mm 140g

Polster für Set-Laden | Pads for set trays | Coussinets pour plateaux à parure

REBRA



**5S/H**

**Karte für Anhänger, hoch**  
Pendant pad, portrait  
*Carte pour pendentif, verticale*  
52 x 35 mm



**5S/TH**

**Karte für Kette mit Anhänger**  
Chain & Pendant Pad  
*Carte pour chaîne avec pendentif*  
52 x 35 mm



**5S/HA9**

**Karte für Anhänger, Haken 765 (gold- oder silberfarben)**  
Pendant pad, hook 765 (gilt or chrome)  
*Carte pour pendentif, crochet 765 (dorés ou chromés)*  
52 x 35 mm



**5S/DH**

**Karte für Ohrhinge**  
Drop earrings pad  
*Carte pour B.O.*  
52 x 35 mm



**5S/WiQ**  
**5S/WiH**

**Winkelkarte für Stecker**  
Angle pad for drop stud earrings  
*Carte recourbée pour clous d'oreilles*  
35 x 52 mm  
52 x 35 mm



**5S/iH**

**Karte für Stecker**  
Pad for drop stud earrings  
*Carte pour clous d'oreilles*  
52 x 35 mm / 35 x 52 mm



**5W**

**Karte für Anhänger**  
Pendant pad  
*Carte pour pendentif*  
35 x 35 mm



**5W/i**

**Karte für Stecker**  
Pad for drop stud earrings  
*Carte pour clous d'oreilles*  
35 x 35 mm



**5W/HA9**

**Karte für Anhänger, Haken 765 (gold- oder silberfarben)**  
Pendant pad, hook 765 (gilt or chrome)  
*Carte pour pendentif, crochet 765 (dorés ou chromés)*  
35 x 35 mm



**5W/i/6**

**Karte für Hängestecker**  
Pad for drop stud earrings  
*Carte pour clous d'oreilles*  
35 x 35 mm



**5W/Wi**

**Winkelkarte für Stecker**  
Angle pad for drop stud earrings  
*Carte recourbée pour clous d'oreilles*  
35 x 35 mm



**5W/D**

**Karte für Ohrhinge**  
Pad for drop earrings  
*Carte pour B.O.*  
35 x 35 mm



**V118H**

**Karte für Anhänger, hoch**  
Pendant pad, portrait  
*Carte pour pendentif, verticale*  
118 x 82 mm



**V118/WiH**

**Winkelkarte für Ohrhinge, hoch**  
Earring angle pad, portrait  
*Carte pour B.O., verticale*  
118 x 82 mm



**V118GA1**

**Karte für Set, Kette mit Anhänger, Armband und Ohrschmuck**  
Pad for chain with pendant, bracelet and earrings  
*Carte pour chaîne avec pendentif, bracelet et B.O.*  
118 x 82 mm



Maßangaben: Länge x Breite x Höhe | Dimensions: Length x Width x Height | Dimensions: Longueur x Largeur x Hauteur

Original Polstergrößen | Actual Pad Sizes | Tailles réelles de coussinets

REBRA

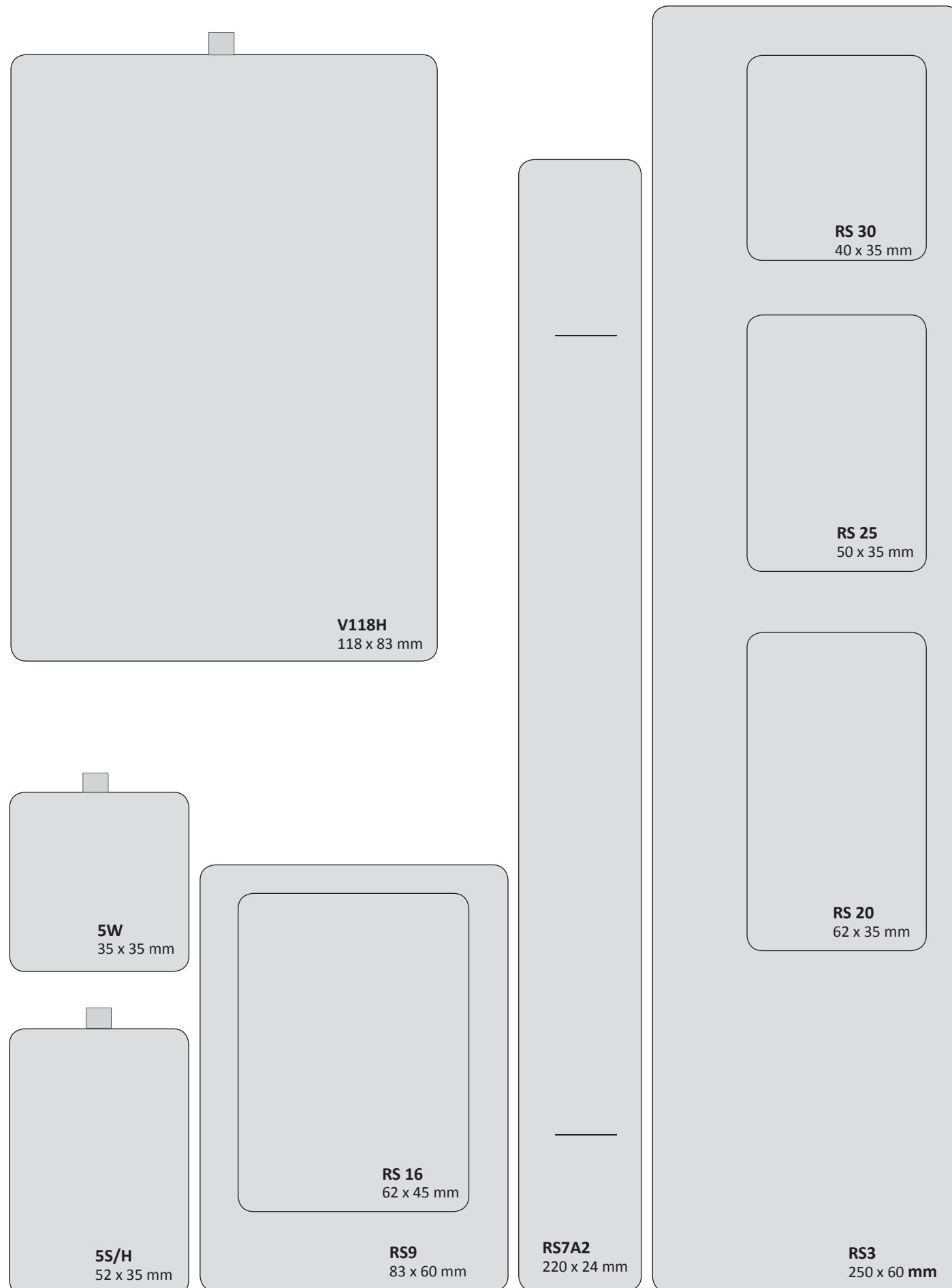

Maßangaben: Länge x Breite x Höhe | Dimensions: Length x Width x Height | Dimensions: Longueur x Largeur x Hauteur

Koffer | Cases | Marmottes

REBRA



## DER VIELSEITIGE

**Softbag Travel Line mit strapazierfähigem „Glencheck“ Stoff in Schwarz. Teleskopgriff, variabler Innenraum.**

Softbag Travel Line with durable fabric „Glencheck“ in black. Telescopic handle, customisable interior

Sac de transport Travel Line avec tissu résistant „Glencheck“ en noir. Poignée télescopique, aménagement intérieur flexible

### FTL-01

Dim. innen/int.:

630 x 320 x 270 mm

Dim. außen/ext.:

700 x 360 x 360 mm

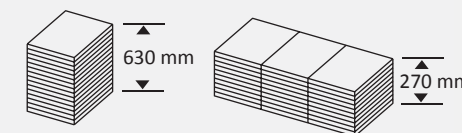

Maßangaben: Länge x Breite x Höhe | Dimensions: Length x Width x Height | Dimensions: Longueur x Largeur x Hauteur



**Softbag Travel Line mit strapazierfähigem „Glencheck“ Stoff in Schwarz. Teleskopgriff, variabler Innenraum.**

Softbag Travel Line with durable fabric „Glencheck“ in black. Telescopic handle, customisable interior  
 Sac de transport Travel Line avec tissu résistant „Glencheck“ en noir. Poignée télescopique, aménagement intérieur flexible

**FTL-02**

Dim. innen/int.:  
 450 x 330 x 170 mm  
 Dim. außen/ext.:  
 530 x 370 x 250 mm

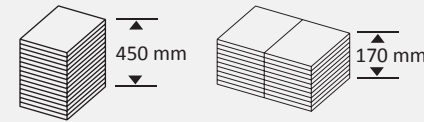

**DER KLASSIKER**

**Koffer, stabile Aluminiumprofile, PVC beschichtetes Pappsperrholzgehäuse, unterschiedliche Oberflächen wählbar**  
 Case, solid aluminium profiles, PVC laminated plywood shell, different surfaces available

Valise, entourage en alu, corps en bois avec surface en PVC, différentes finitions extérieures possibles

**FAF-RE1**

Dim. innen/int.:  
 548 x 208 x 375 mm 4 kg

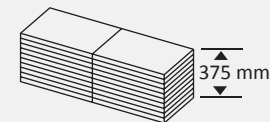

**DER STYLISCHE**

**Schalenkoffer Air-Line, in zwei Farben und zwei Größen erhältlich**  
 Solid Multiwheel trolley Air-Line, available in two colours and two sizes  
 Valise rigide Air-Line, en deux couleurs et deux tailles disponibles

**FLI-01**

Dim. innen/int.:  
 500 x 400 x 260 mm  
 Dim. außen/ext.:  
 545 x 495 x 315 mm

**FLI-02**

Dim. innen/int.:  
 580 x 425 x 225 mm  
 Dim. außen/ext.:  
 600 x 450 x 280 mm

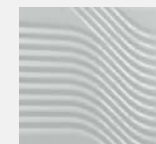
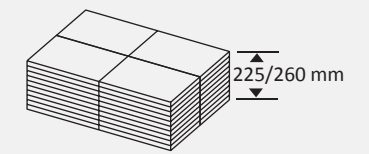

Attractive details



Combination lock protects your contents



Schwarz  
 Black  
 noir



Sturdy corner wheels

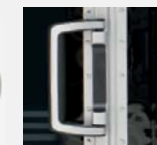

Ergonomic handle



Silber  
 Silver  
 argenté

**Innenraum mit hochwertigem Stoff ausgekleidet, zusätzliche Einlagen möglich**

Inside lined with high-quality textile, additional inserts possible  
 habillage intérieur en tissu de grande qualité, possibilité de fabriquer des mousses compartimentées

Maßangaben: Länge x Breite x Höhe | Dimensions: Length x Width x Height | Dimensions: Longueur x Largeur x Hauteur

## DER KOMPAKTE



**Boardcase, ABS-Material mit schwarzem Schaumstoff ausgeschlagen, für 2 Ladenstapel jeweils à 165 mm**

Boardcase, ABS-Material, lined with black foam to take 2 stacks of trays height 165 mm  
*Bagage cabine en ABS, habillage intérieur de mousse noire, espace utile pour 2 piles de plateaux, hauteur max. 165mm*

**RK637**

Dim. innen/int. ca.: 440 x 340 x 165 mm



Case available in black or silver



High quality profile alu nature anodized or black powder coated

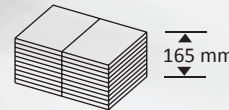

BOARDCASE

## DAS RAUMWUNDER

**Rebra Koffer, ABS-Material mit schwarzem Schaumstoff ausgeschlagen, für 3 Ladenstapel jeweils 390 mm**

Case, ABS-Material, lined with black foam to take 3 stacks of trays height 390 mm  
*Valise Rebra en ABS, habillage intérieur de mousse noire, espace utile pour 3 piles de plateaux, hauteur max. 390mm*

**RK635**

Dim. innen/int. ca.: 622 x 407 x 275 mm

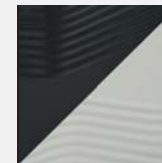

Case available in black or silver



High quality profile Alu anodized or black

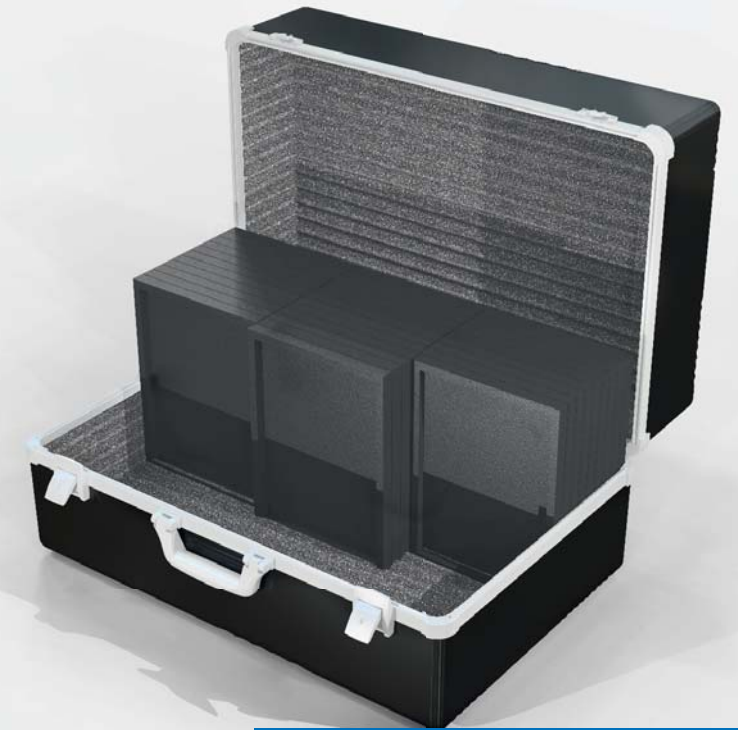
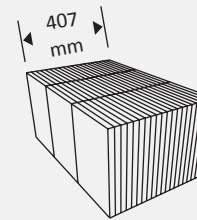

LARGE SIZE

ROBUST

INNOVATIVE AND MODERN DESIGN

STRONG METALLIC HANDLE

## DER ALLROUNDER



**Rebra Koffer, ABS-Material mit schwarzem Schaumstoff ausgeschlagen, für 2 Ladenstapel jeweils 390 mm**

Case, ABS-Material, lined with black foam to take 2 stacks of trays height 390 mm  
*Valise Rebra en ABS, habillage intérieur de mousse noire, espace utile pour 2 piles de plateaux, hauteur max. 390mm*

**RK636**

Dim. innen/int.: 567 x 407 x 205 mm



Case available in black or silver



High quality profile Alu anodized or black

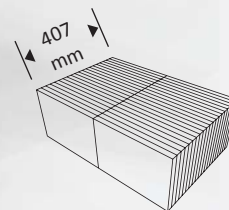

MEDIUM SIZE



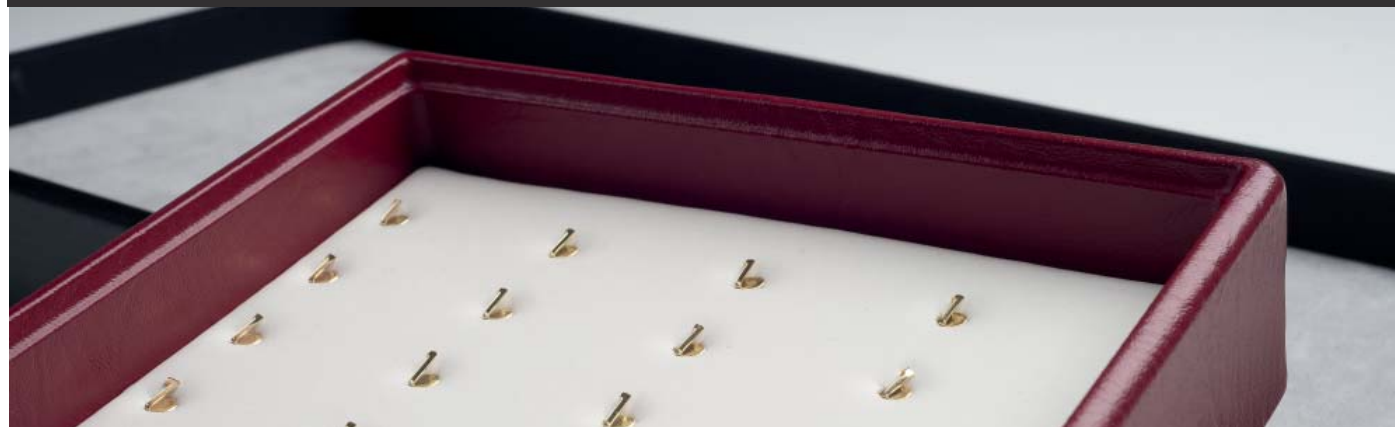

**Manschettenknopfhalter „Klammer“, transparent. VP-Einheit: 100 Stück**  
Cufflink bracket, transparent. Packing unit: 100 pieces  
*Attaches pour boutons de manchettes, transparents. Emballage: 100 pièces*

**KL51**



**Manschettenknopfhalter „Bügel“ transparent. VP-Einheit: 100 Stück**  
Cufflink bracket, transparent (Packing unit: 100 pieces). Packing unit: 100 pieces  
*Crochets souples pour boutons de manchettes, transparents. Emballage: 100 pièces*

**KL53**



**Clip für 1 Ring, Befestigung von Armbändern, Krawattennadeln, Sets etc. VP-Einheit: 100 Stück. In Transparent, Schwarz oder Weiß.**  
Clip for 1 ring, bracket for bracelets, tie-pins, sets, etc., Packing unit 100 pieces, clear, black or white.  
*Clip pour 1 bague ou pour fixer bracelet, parure, épingle à cravate, etc. Emballage: 100 pièces. Transp., noir et blanc*

**KL60/8** L: 8 mm



**Clip für 2 Ringe, Befestigung von Armbändern, Krawattennadeln, Sets etc. VP-Einheit: 100 Stück. In Transparent, Schwarz oder Weiß.**  
Clip for 2 rings, bracket for bracelets, tie-pins, sets, etc., Packing unit 100 pieces, clear, black or white.  
*Clip pour 2 bagues ou pour fixer bracelet, bracelet, parure, épingle à cravate, etc. Emballage: 100 pièces. Transp., noir et blanc*

**KL60/14** L: 14 mm



**Polyklammer für Ring, transparent. VP-Einheit: 100**  
Poly-Clip for ring, transparent. Packing unit 100 pieces  
*Poly-Clip pour bague, transp. Emballage: 100 pièces*

**KL1000**



**Anhängerhaken. VP-Einheit: 100**  
Hooks for pendants. Packing unit 100 pieces  
*Crochets pour pendentifs. +Emballage: 100 pièces.*

**751G** gold / gilt / dorés  
**751W** silber / chrome / chromés

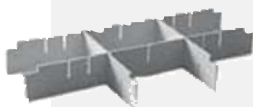

**Rastersteg (weiß), für Lade RL1/48, kurz**  
Adjustable dividers (white), for tray RL1/48, short  
*Séparation amovible (blanche), pour plateau, RL1/48, courte*

**RD748K**

**Rastersteg (weiß), für Lade RL1/48, lang**  
Adjustable dividers (white), for tray RL1/48, long  
*Séparation amovible (blanche), pour plateau, RL1/48, longue*

**RD748L**



**Preisklappe für Lade RL16**  
Pricing system for tray RL16  
*Plaquette d'affichage de prix pour plateau RL16*

**RL16P**



**Klettverschlussband (Haft + Flausch), per Lfm**  
Velcro strips, tape per meter  
*Bande velcro, au mètre*

**7030/7031** 20 mm



**Klettband-Gurte, schwarz**  
Velcro strap in black  
*Courroie velcro noire*

**7025/100** 1000 mm  
**7025/130** 1300 mm  
**7025/150** 1500 mm  
**7025/180** 1800 mm



**Abnehmbarer Trolley mit Teleskopgriff für Montage an Koffer FAF-RE1. Lieferbar in schwarz, Rollendurchmesser: 125 mm Griffgesamtlänge: 980 mm**  
Detachable trolley with telescopic handle to be fitted on case FAF-RE1. Available in black, diameter of wheels: 120 mm, length of handle: 980 mm  
*Trolley amovible avec poignée télescopique pour marmottes FAF-RE1. Livrable en noir Diamètre des roues: 120 mm long. poignée: 980 mm*

**FA-TA125**

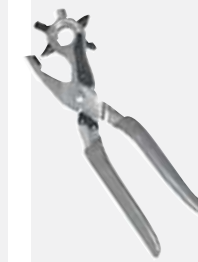

**REBRA-Universalzange für Anhängerhaken, Creolenhaken, Ring-Clip, Ohrringschlitz, incl. Zubehörbox**  
REBRA universal pincers enabling you to attach various accessories. Price includes tool box  
*Pince universelle REBRA pour toutes les fixations de notre système, boîte outillage incluse*

**DS/Z1**

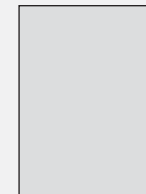

**4 mm Bodenpolster, selbstklebend (auf Rückseite der Lade anbringen)**  
4 mm self-adhesive base padding. To be attached to the exterior of tray.  
*Mousse 4 mm autocollante pour le fond extérieur du plateau*

**RD1/4**

**Farbzuschlag für Lackierungen in Sonderfarbe (ab 20 St. möglich)**  
Tray surcharge for special colours (minimum order quantity 20 pcs.)  
*Supplément pour plateaux laqué en couleur spéciale (quantité minimum de commande de 20 pcs.)*

**RD/F1**



VARIETY OF MATERIALS

VARIETY OF COLOURS

VARIETY OF INTERIORS

3 TRAY SIZES

## SERIE VARIO NORM

Flexibilität als Markenzeichen, das ist Vario Norm. Zur Inszenierung einzelner Schmuckstücke oder ganzer Sets. Die Kombination an Materialien und Farben bietet Ihnen nahezu unbegrenzte Möglichkeiten zur Gestaltung Ihrer eigenen Präsentationsladen und der darauf abgestimmten Koffer.

The Vario Norm presentation series is characterised by flexibility. For staging individual pieces of jewellery or complete sets. The combination of materials and colours offers nearly unlimited possibilities for designing your own presentation trays and matching cases.

Vario Norm représente vraiment la polyvalence. Pour mettre en valeur un bijou seul ou une collection. La combinaison de matériaux et de couleurs offre un champ de création pratiquement illimité dans le domaine des plateaux de présentation et des marmottes.

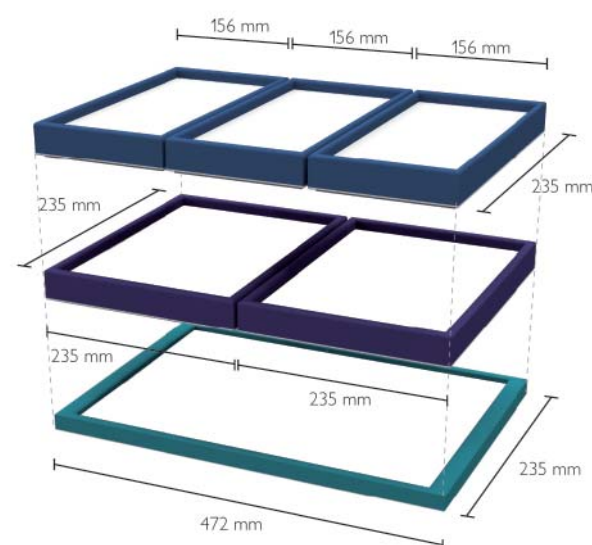

### 1 flaches Taftfach

1 flat taffeta compartment  
1 compartiment taffetas plat

**4230A** 472 x 235 x 18/25 mm

### 1 ausgeschlagenes Fach ca. 458 x 221 mm (nicht für Karten)

1 lined compartment approx. 458 x 221 mm (not for pads)  
1 compartiment gainé environ 458 x 221 mm (pas pour cartes)

**4230C** 472 x 235 x 18/25 mm



### Wattierte Platte mit 2 Ausheber

Plain pad with 2 tabs  
Carte gainée, rembourrée à 2 languettes

**5B** 459 x 222 mm



### 1 Taftfach, mit Ausgleich

1 taffeta compartment with inner edging  
1 compartiment taffetas avec entourage intérieur

**4100** 235 x 235 x 18/25 mm



### 1 ausgeschlagenes Fach ca. 221 x 221 mm (nicht für Karten)

1 lined compartment approx. 221 x 221 mm (not for pads)  
1 compartiment gainé environ 221 x 221 mm (pas pour cartes)

**4100C** 235 x 235 x 18/25 mm



### Platte, glatt

Plain pad  
Carte gainée, rembourrée

**5A** 209 x 209 mm

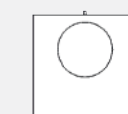

### Platte mit rundem Tambour (Ø 120mm)

Pad with a round raised neck form (Ø 120mm)  
Idem mais avec tambour surélevé rond (Ø 120mm)

**5A/TA** 209 x 209 mm

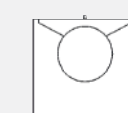

### Wie Modell 5A/TA, zusätzlich mit Gummispanner

Like 5A/TA plus elastics at the top  
Comme 5A/TA plus une boucle élastique en haut

**5A/TA/5** 209 x 209 mm



### 1 flaches Taftfach

1 flat taffeta compartment  
1 compartiment taffetas plat

**4700** 235 x 156 x 18/25 mm



### 1 ausgeschlagenes Fach ca. 221 x 142 mm (nicht für Karten)

1 lined compartment approx. 221 x 142 mm (not for pads)  
1 compartiment gainé environ 221 x 142 mm (pas pour cartes)

**4700C** 235 x 156 x 18/25 mm

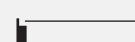

### 1 tiefes Taftfach (mit Hohlraum unter Karte)

1 deep taffeta compartment (with recess below pad)  
1 compartiment taffetas surélevé (avec de l'espace sous cartouches)

**4700V** 235 x 156 x 25 mm

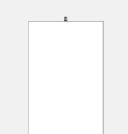

### Wattierte Platte

Plain pad, portrait  
Carte gainée rembourrée, verticale

**5G/H** 221 x 143 mm

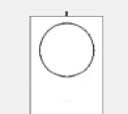

### Platte mit rundem Tambour (140 x 84)

Pad with a round raised neck form  
Idem mais avec tambour rond surélevé

**5G/TA** 221 x 143 mm

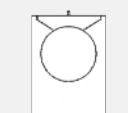







### Wie Modell 5G/TA, zusätzlich mit Gummispanner





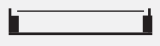
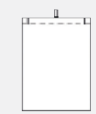

Like 5G/TA plus elastics at the top  
Comme 5G/TA plus une boucle élastique en haut



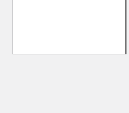

**5G/TA/5** 221 x 143 mm

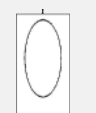
Maßangaben: Länge x Breite x Höhe | Dimensions: Length x Width x Height | Dimensions: Longueur x Largeur x Hauteur

	<p><b>3 Taftfächer</b> 3 taffeta compartments <i>3 compartiments taffetas plats</i></p> <p><b>4244</b> 472 x 235 x 18/25 mm</p>		<p><b>Platte, hoch</b> Plain pad, portrait <i>Carte gainée rembourrée, verticale</i></p> <p><b>5C/H</b> 221 x 151 mm</p>
	<p><b>3 ausgeschlagene Fächer ca. 151 x 220 mm (nicht für Karten)</b> 3 lined compartments approx. 151 x 220 mm (not for pads) <i>3 compartiments gainés env. 151 x 220 mm (non destinés à des cartes)</i></p> <p><b>4244C</b> 472 x 235 x 18/25 mm</p>		<p><b>Platte mit rundem Tambour (Ø 120 mm)</b> Pad with a round raised neck form (Ø 120 mm) <i>Idem mais avec tambour surélevé rond (Ø 120mm)</i></p> <p><b>5C/TA</b> 221 x 151 mm</p>
			<p><b>Wie Modell 5C/TA, zusätzlich mit Gummispanner</b> Like 5C/TA plus elastics at the top <i>Comme 5C/TA plus une boucle élastique en haut</i></p> <p><b>5C/TA/5</b> 221 x 151 mm</p>

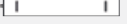
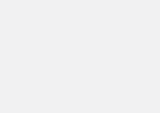
	<p><b>2 Taftfächer</b> 2 taffeta compartments <i>2 compartiments taffetas plats</i></p> <p><b>4706</b> 235 x 156 x 18/25 mm</p>		<p><b>Karte für Anhänger, hoch</b> Plain pad, portrait <i>Carte pour pend., verticale</i></p> <p><b>5T/H</b> 143 x 108 mm</p>
	<p><b>2 ausgeschlagene Fächer ca. 107 x 142 mm (nicht für Karten)</b> 2 lined compartments approx. 107 x 142 mm (not for pads) <i>2 compartiments gainés env. 107 x 142 mm (non destinés à des cartes)</i></p> <p><b>4706C</b> 235 x 156 x 18/25 mm</p>		<p><b>Karte für Broschen, quer</b> Pad for brooch, landscape <i>Carte pour broche, horizontale</i></p> <p><b>5T/Q</b> 108 x 143 mm</p>
	<p><b>2 tiefe Taftfächer (mit Hohlraum unter Karte)</b> 2 deep taffeta compartments (with recess below pad) <i>2 compartiments taffetas surélevés (avec de l'espace sous cartouche)</i></p> <p><b>4706V</b> 235 x 156 x 25 mm</p>		<p><b>Karte für Kette mit Anhänger, hoch</b> Pad for chain with pendant, portrait <i>Carte pour chaîne avec pendentif, verticale</i></p> <p><b>5T/TH</b> 143 x 108 mm</p>
			<p><b>Karte für Kette mit Anhänger, quer</b> Pad for chain with pendant, landscape <i>Carte pour chaîne avec pendentif, horizontale</i></p> <p><b>5T/TQ</b> 108 x 143 mm</p>

	<p><b>2 Taftfächer</b> 2 taffeta compartments <i>2 compartiments taffetas plats</i></p> <p><b>4101</b> 235 x 235 x 18/25 mm</p>		<p><b>Platte, hoch</b> Plain pad, portrait <i>Carte lisse gainée rembourrée, verticale</i></p> <p><b>5D/H</b> 209 x 105 mm</p>
	<p><b>2 ausgeschlagene Fächer ca. 221 x 104 mm (nicht für Karten)</b> 2 lined compartments approx. 221 x 104 mm (not for pads) <i>2 compartiments gainés env. 221 x 104 mm (non destinés à des cartes)</i></p> <p><b>4101C</b> 235 x 235 x 18/25 mm</p>		<p><b>Platte, quer</b> Plain pad, landscape <i>Carte lisse gainée rembourrée, horizontale</i></p> <p><b>5D/Q</b> 105 x 209 mm</p>
	<p><b>2 tiefe Taftfächer (mit Hohlraum unter Karte)</b> 2 deep taffeta compartments (with recess below pad) <i>2 compartiments taffetas surélevés (avec de l'espace sous cartouche)</i></p> <p><b>4101V</b> 235 x 235 x 25 mm</p>		<p><b>Platte mit 2 Ketteneinschnitten, rückwärtige Tasche</b> With 2 slits for chain, back pocket <i>Avec 2 fentes pour chaîne, poche au dos</i></p> <p><b>5D/TH</b> 209 x 105 mm</p>
			<p><b>Platte mit ovalem Tambour (141 x 85 mm)</b> Pad with an oval raised neck form <i>Idem mais avec tambour surélevé oval</i></p> <p><b>5D/TA</b> 209 x 105 mm</p>
			<p><b>Wie Modell 5D/TA, zusätzlich mit Gummispanner</b> Pad with an oval raised neck form and elastics at the top <i>comme modèle 5D/TA plus une boucle élastique en haut</i></p> <p><b>5D/TA/5</b> 209 x 105 mm</p>

	<p><b>12 Taftfächer</b> 12 taffeta compartments <i>12 compartiments taffetas plats</i></p> <p><b>4239</b> 472 x 235 x 18 mm</p>		<p><b>Karte für Armband mit 2 Gummis</b> Pad with 2 elastics for bracelet <i>Carte rembourrée gainée munie de 2 élastiques</i></p> <p><b>5E</b> 35 x 210 mm</p>
	<p><b>12 ausgeschlagene Fächer ca. 34 x 220 mm (nicht für Karten)</b> 12 lined compartments approx. 34 x 220 mm (not for pads) <i>12 compartiments gainés env. 34 x 220 mm (non destinés à des cartes)</i></p> <p><b>4239C</b> 472 x 235 x 18/25 mm</p>		
	<p><b>6 flache Taftfächer</b> 6 flat taffeta compartments <i>6 compartiments taffetas plats</i></p> <p><b>4107</b> 235 x 235 x 18 mm</p>		<p><b>4 flache Taftfächer</b> 4 flat taffeta compartments <i>4 compartiments taffetas plats</i></p> <p><b>4711</b> 235 x 156 x 18 mm</p>
	<p><b>6 ausgeschlagene Fächer ca. 34 x 220 mm (nicht für Karten)</b> 6 lined compartments approx. 34 x 220 mm (not for pads) <i>6 compartiments gainés env. 34 x 220 mm (non destinés à des cartes)</i></p> <p><b>4107C</b> 235 x 235 x 18/25 mm</p>		<p><b>4 ausgeschlagene Fächer ca. 220 x 34 mm (nicht für Karten)</b> 4 lined compartments approx. 220 x 34 mm (not for pads) <i>4 compartiments gainés env. 220 x 34 mm (non destinés à des cartes)</i></p> <p><b>4711C</b> 235 x 156 x 18/25 mm</p>

Maßangaben: Länge x Breite x Höhe | Dimensions: Length x Width x Height | Dimensions: Longueur x Largeur x Hauteur



**16 flache Taftfächer**  
16 flat taffeta compartments  
16 compartiments taffetas plats

**4238** 472 x 235 x 18 mm

**16 ausgeschlagene Fächer**  
**ca. 24 x 220 mm (nicht für Karten)**  
16 lined compartments  
approx. 24 x 220 mm (not for pads)  
16 compartiments gainés env. 24 x 220 mm  
(non destinés à des cartes)

**4238C** 472 x 235 x 18/25 mm



**8 flache Taftfächer**  
8 flat taffeta compartments  
8 compartiments taffetas plats

**4108** 235 x 235 x 18 mm



**8 ausgeschlagene Fächer**  
**ca. 24 x 220 mm (nicht für Karten)**  
8 lined compartments  
approx. 224 x 220 mm (not for pads)  
8 compartiments gainés env. 24 x 220 mm  
(non destinés à des cartes)

**4108C** 235 x 235 x 18/25 mm

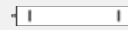

**Karte für Armband mit 2 Gummis**  
Pad with 2 elastics for bracelet  
Carte rembourrée gainée munie de 2 élastiques

**5F** 25 x 210 mm



**5 flache Taftfächer**  
5 flat taffeta compartments  
5 compartiments taffetas plats

**4712** 235 x 156 x 18 mm



**5 ausgeschlagene Fächer**  
**ca. 220 x 24 mm (nicht für Karten)**  
5 lined compartments  
approx. 220 x 24 mm (not for pads)  
5 compartiments gainés env. 220 x 24 mm  
(non destinés à des cartes)

**4712C** 235 x 156 x 18/25 mm



**16 flache Taftfächer**  
16 flat taffeta compartments  
16 compartiments taffetas plats

**4140** 235 x 235 x 18/25 mm



**16 ausgeschlagene Fächer**  
**ca. 110 x 24 mm (nicht für Karten)**  
16 lined compartments  
approx. 110 x 24 mm (not for pads)  
16 compartiments gainés env. 110 x 24 mm  
(non destinés à des cartes)

**4140C** 235 x 235 x 18/25 mm



**Karte für Anhänger/Brosche**  
Pad for pendant/brooch  
Carte pour pend./broche

**5Z** 105 x 25 mm



**Karte für Krawattenschieber**  
Pad for tie-bar  
Carte pour pince-cravatte

**5Z/F** 105 x 25 mm



**10 flache Taftfächer**  
10 flat taffeta compartments  
10 compartiments taffetas plats

**4773** 235 x 156 x 18/25 mm



**10 ausgeschlagene Fächer**  
**ca. 109 x 24 mm (nicht für Karten)**  
10 lined compartments  
approx. 109 x 24 mm (not for pads)  
10 compartiments gainés env. 109 x 24 mm  
(non destinés à des cartes)

**4773C** 235 x 156 x 18/25 mm



**6 flache Taftfächer**  
6 flat taffeta compartments  
6 compartiments taffetas plats

**4102** 235 x 235 x 18/25 mm



**6 ausgeschlagene Fächer ca. 104 x 69 mm (nicht für Karten)**  
6 lined compartments approx. 104 x 69 mm (not for pads)  
6 compartiments gainés env. 104 x 69 mm (non destinés à des cartes)

**4102C** 235 x 235 x 18/25 mm



**4 flache Taftfächer**  
4 flat taffeta compartments  
4 compartiments taffetas plats

**4701** 235 x 156 x 18/25 mm



**4 ausgeschlagene Fächer ca. 108 x 69 mm (nicht für Karten)**  
4 lined compartments approx. 108 x 69 mm (not for pads)  
4 compartiments gainés env. 108 x 69 mm (non destinés à des cartes)

**4701C** 235 x 156 x 18/25 mm



**6 tiefe Taftfächer**  
6 deep taffeta compartments  
6 compartiments taffetas surélevés

**4102V** 235 x 235 x 25 mm



**4 tiefe Taftfächer (mit Hohlraum unter Karte)**  
4 deep taffeta compartments (with recess below pad)  
4 compartiments taffetas surélevés (avec de l'espace sous cartouche)

**4701V** 235 x 156 x 25 mm



**Karte für Anhänger, hoch**  
Pad for pendant, portrait  
Carte pour pend., verticale  
**5H/H** 105 x 70 mm



**Karte für Broschen, quer**  
Pad for brooch, landscape  
Carte pour broche, horizontale

**5H/Q** 70 x 105 mm



**Winkelkarte für Stecker**  
Angle Pad for drop stud earrings  
Carte recourbée pour clous d'oreilles

**5H/WiH** 105 x 70 mm

**5H/WiQ** 70 x 105 mm



**Erhöhte Karte für Ohrringe**  
Raised Pad for earrings  
Cartouche surélevée pour B.O.

**5H/Y** 105 x 70 mm



**Karte für Clips**  
Pad for clips  
Carte pour clips

**5H/B2Q** 70 x 105 mm



**Karte für Kette mit Anhänger**  
Pad for chain with pendant  
Carte pour chaîne avec pend.

**5H/TH** 105 x 70 mm

**5H/TQ** 70 x 105 mm



**4 flache Taftfächer**  
4 flat taffeta compartments  
4 compartiments taffetas plats

**41A4** 235 x 235 x 18/25 mm



**4 ausgeschlagene Fächer ca. 104 x 104 mm (nicht für Karten)**  
4 lined compartments approx. 104 x 104 mm (not for pads)  
4 compartiments gainés env. 104 x 104 mm (non destinés à des cartes)

**41C4** 235 x 235 x 18/25 mm



**Karte für Anhänger/Brosche**  
Pad for pendant/brooch  
Carte pour pend./broche

**5M** 105 x 105 mm



**Karte für Kette mit Anhänger**  
Pad for chain with pendant  
Carte pour chaîne avec pend.

**5M/T** 105 x 105 mm

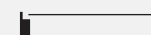

**4 tiefe Taftfächer (mit Hohlraum unter Karte)**  
4 deep taffeta compartments (with recess below pad)  
4 compartiments taffetas surélevés (avec de l'espace sous cartouche)

**41A4V** 235 x 235 x 18/25 mm

Maßangaben: Länge x Breite x Höhe | Dimensions: Length x Width x Height | Dimensions: Longueur x Largeur x Hauteur



**9 flache Taftfächer**  
9 flat taffeta compartments  
*9 compartiments taffetas plat*

**4103** 235 x 235 x 18/25 mm



**Karte für Anhänger/Brosche**  
Pad for pendant/brooch  
*Carte pour pend./broche*

**5L** 70 x 70 mm



**9 ausgeschlagene Fächer ca. 69 x 69 mm (nicht für Karten)**  
9 lined compartments approx. 69 x 69 mm (not for pads)  
*9 compartiments gainés env. 69 x 69 mm (non destinés à des cartes)*

**4103C** 235 x 235 x 18/25 mm



**Winkelkarte für Stecker**  
Angle Pad for drop stud earrings/hoops  
*Carte recourbée pour clous d'oreilles*

**5L/Wi** 70 x 70 mm



**6 flache Taftfächer**  
6 flat taffeta compartments  
*6 compartiments taffetas plat*

**4702** 235 x 156 x 18/25 mm



**Erhöhte Karte für Ohrringe**  
Raised Pad for earrings  
*Cartouche surélevée pour B.O.*

**5L/Y** 70 x 70 mm



**6 ausgeschlagene Fächer ca. 69 x 69 mm (nicht für Karten)**  
6 lined compartments approx. 69 x 69 mm (not for pads)  
*6 compartiments gainés env. 69 x 69 mm (non destinés à des cartes)*

**4702C** 235 x 156 x 18/25 mm



**9 tiefe Taftfächer (mit Hohlraum unter Karte)**  
9 deep taffeta compartments (with recess below pad)  
*9 compartiments taffetas surélevés (avec de l'espace sous cartouche)*

**4103V** 235 x 235 x 25 mm



**Karte für Clips**  
Pad for clips  
*Carte pour clips*

**5L/B3** 70 x 70 mm

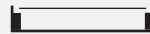

**6 tiefe Taftfächer (mit Hohlraum unter Karte)**  
6 deep taffeta compartments (with recess below pad)  
*6 compartiments taffetas surélevés (avec de l'espace sous cartouche)*

**4702V** 235 x 156 x 25 mm



**Karte für Ketten mit Anhänger**  
Pad for chain with pendant  
*Carte pour chaîne avec pend*

**5L/T** 70 x 70 mm



**16 flache Taftfächer**  
16 flat taffeta compartments  
*16 compartiments taffetas plat*

**4109** 235 x 235 x 18/25 mm



**Karte für Anhänger/Brosche**  
Pad for pendant/brooch  
*Carte pour pend./broche*

**5i** 52 x 52 mm



**16 ausgeschlagene Fächer ca. 51 x 51 mm (nicht für Karten)**  
16 lined compartments approx. 51 x 51 mm (not for pads)  
*16 compartiments gainés env. 51 x 51 mm (non destinés à des cartes)*

**4109C** 235 x 235 x 18/25 mm



**Winkelkarte für Ohrschmuck**  
Angle Pad for drop stud earrings/hoops  
*Carte recourbée pour clous d'oreilles*

**5i/Wi** 52 x 52 mm



**Erhöhte Karte für Ohrringe**  
Raised Pad for earrings  
*Cartouche surélevée pour B.O.*

**5i/Y** 52 x 52 mm



**16 tiefe Taftfächer (mit Hohlraum unter Karte)**  
16 deep taffeta compartments (with recess below pad)  
*16 comp. taffetas surélevés (avec de l'espace sous cartouches)*

**4109V** 235 x 235 x 25 mm



**Karte für Ketten mit Anhänger**  
Pad for chain with pendant  
*Carte pour chaîne avec pend.*

**5i/T** 52 x 52 mm



**Karte für Clips**  
Pad for clips  
*Carte pour clips*

**5i/B2** 52 x 52 mm



**12 Taftfächer**  
12 taffeta compartments  
*12 compartiments taffetas*

**4104** 235 x 235 x 18/25 mm



**Karte für Anhänger, hoch**  
Pad for pendant, portrait  
*Carte pour pend., verticale*

**50/H** 70 x 52 mm



**12 ausgeschlagene Fächer ca. 51 x 69 mm (nicht für Karten)**  
12 lined compartments approx. 51 x 69 mm (not for pads)  
*12 compartiments gainés environ 51 x 69 mm (pas pour cartes)*

**4104C** 235 x 235 x 18/25 mm



**Karte für Broschen, quer**  
Pad for brooch, landscape  
*Carte pour broche, horizontale*

**50/Q** 52 x 70 mm



**8 flache Taftfächer**  
8 flat taffeta compartments  
*8 compartiments taffetas plats*

**4703** 235 x 156 x 18/25 mm



**Winkelkarte für Stecker**  
Angle Pad for drop stud earrings  
*Carte recourbée pour clous d'oreilles*



**50/WiH** 70 x 52 mm



**Erhöhte Karte für Ohrringe**  
Raised Pad for earrings  
*Cartouche surélevée pour B.O.*

**50/Y** 70 x 52 mm



**8 ausgeschlagene Fächer ca. 51 x 69 mm (nicht für Karten)**  
8 lined compartments approx. 51 x 69 mm (not for pads)  
*8 compartiments gainés environ 51 x 69 mm (pas pour cartes)*

**4703C** 235 x 156 x 18/25 mm



**Karte für Creolen + Klammer 718**  
Pad for creole earrings + clip 718  
*Carte pour créoles + clip 718*

**50/C2/Q** 52 x 70 mm



**4 flache Poly-Fächer**  
4 flat poly compartments  
*4 compartiments poly plat*

**4704** 70 x 52 x 18/25 mm



**Karte für Manschettenknöpfe**  
Pad for cufflinks  
*Carte pour boutons de manchettes*

**50/A4** 52 x 70 mm



**6 flache Poly-Fächer**  
6 flat poly compartments  
*6 compartiments poly plat*

**4155** 70 x 52 x 18/25 mm



Maßangaben: Länge x Breite x Höhe | Dimensions: Length x Width x Height | Dimensions: Longueur x Largeur x Hauteur



**12 tiefe Taftfächer (mit Hohlraum unter Karte)**  
12 deep taffeta compartments (with recess below pad)  
*12 comp. taffetas surélevés (avec de l'espace sous cartouches)*

**4104V** 235 x 235 x 25 mm



**Karte für Clips**  
Pad for clips  
*Carte pour clips*

**50/B2Q** 52 x 70 mm



**6 tiefe Polyfächer (mit Hohlraum unter Karte)**  
6 deep poly compartments (with recess below pad)  
*6 comp. poly surélevés (avec de l'espace sous cartouches)*

**4155V** 235 x 235 x 25 mm



**Karte für Ohringe**  
Pad for drop earrings  
*Carte pour B.O.*

**50/DH** 70 x 52 mm



**8 tiefe Taftfächer (mit Hohlraum unter Karte)**  
8 deep taffeta compartments (with recess below pad)  
*8 comp. taffetas surélevés (avec de l'espace sous cartouches)*

**4703V** 235 x 156 x 25 mm



**Karte für Stecker**  
Pad for drop stud earrings  
*Carte pour clous d'oreilles*

**50/iH** 70 x 52 mm  
**50/iQ/M** 52 x 70 mm



**4 tiefe Polyfächer (mit Hohlraum unter Karte)**  
4 deep poly compartments (with recess below pad)  
*4 comp. poly surélevés (avec de l'espace sous cartouches)*

**4704V** 235 x 156 x 25 mm



**Karte für Ketten mit Anhänger**  
Pad for chain with pendant  
*Carte pour chaîne avec pend.*



**50/TH** 70 x 52 mm  
**50/TQ** 52 x 70 mm



**24 flache Taftfächer**  
24 flat taffeta compartments  
*24 compartiments taffetas plats*

**4105** 235 x 235 x 18/25 mm



**Karte für Anhänger, hoch**  
Pad for pendant, portrait  
*Carte pour pend., verticale*

**5S/H** 52 x 35 mm



**24 ausgeschlagene Fächer ca. 51 x 34 mm (nicht für Karten)**  
24 lined compartments approx. 51 x 34 mm (not for pads)  
*24 compartiments gainés env. 51 x 34mm (non destinés à des cartes)*

**4105C** 235 x 235 x 18/25 mm



**Karte für Broschen, quer**  
Pad for brooch, landscape  
*Carte pour broche, horizontale*

**5S/Q** 35 x 52 mm



**16 flache Taftfächer**  
16 flat taffeta compartments  
*16 compartiments taffetas plats*

**4705** 235 x 156 x 18/25 mm



**Winkelkarte für Stecker**  
Angle Pad for drop stud earrings  
*Carte recourbée pour clous d'oreilles*



**5S/WiH** 52 x 35 mm



**16 ausgeschlagene Fächer ca. 51 x 34 mm (nicht für Karten)**  
16 lined compartments approx. 51 x 34 mm (not for pads)  
*16 compartiments gainés env. 51 x 34mm (non destinés à des cartes)*

**4705C** 235 x 156 x 18/25 mm



**5S/WiQ** 35 x 52 mm



**15 flache Polyfächer**  
15 flat poly compartments  
*15 compartiments poly plats*

**4154** 235 x 235 x 18/25 mm



**Erhöhte Karte für Ohringe**  
Raised Pad for earrings  
*Cartouche surélevée pour B.O.*

**5S/V** 52 x 35 mm



**9 flache Polyfächer**  
9 flat poly compartments  
*9 compartiments poly plat*

**4707** 235 x 156 x 18/25 mm



**Karte für Manschettenknöpfe**  
Pad for cufflinks  
*Carte pour boutons de manchettes*

**5S/A4** 35 x 52 mm



**24 tiefe Taftfächer (mit Hohlraum unter Karte)**  
24 deep taffeta compartments (with recess below pad)  
*24 compartiments taffetas surélevés (avec de l'espace sous cartouches)*

**4105V** 235 x 235 x 25 mm



**Karte für Anhänger, Haken 765**  
Pad for pendant, Hook 765  
*Carte pour pend., Crochet 765*

**5S/HA9** 52 x 35 mm



**15 tiefe Polyfächer (mit Hohlraum unter Karte)**  
15 deep poly compartments (with recess below pad)  
*15 compartiments poly surélevés (avec de l'espace sous cartouches)*

**4154V** 235 x 235 x 25 mm



**Karte für Clips**  
Pad for clips  
*Carte pour clips*

**5S/B2Q** 35 x 52 mm

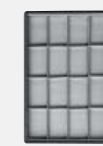

**16 tiefe Taftfächer (mit Hohlraum unter Karte)**  
16 deep taffeta compartments (with recess below pad)  
*16 compartiments taffetas surélevés (avec de l'espace sous cartouches)*

**4705V** 235 x 156 x 25 mm



**Karte für Creolen + Klammer 718**  
Pad for creole earrings + clip 718  
*Carte pour créoles + clip 718*

**5S/C2/Q** 35 x 52 mm



**9 tiefe Polyfächer**  
9 deep poly compartments  
*9 compartiments poly surélevés*

**4707V** 235 x 156 x 25 mm



**Karte für Ohringe**  
Pad for drop earrings  
*Carte avec fentes pour B.O.*

**5S/DH** 52 x 35 mm

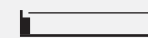

**Karte für Stecker**  
Pad for drop stud earrings  
*Carte pour clous d'oreilles*



**5S/iH** 52 x 35 mm



**5S/iQ/M** 35 x 52 mm



**Karte für Anhänger, hoch**  
Pad for pendant, portrait  
*Carte pour pend., verticale*

**5S/TH** 52 x 35 mm

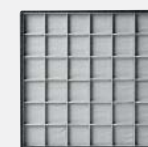

**36 flache Taftfächer**  
36 flat taffeta compartments  
*36 compartiments taffetas plats*

**4106** 235 x 235 x 18/25 mm



**Karte für Anhänger/Brosche**  
Pad for pendant/brooch  
*Carte pour pend./broche*

**5W** 35 x 35 mm



**36 ausgeschlagene Fächer ca. 34 x 34 mm (nicht für Karten)**  
36 lined compartments approx. 34 x 34 mm (not for pads)  
*36 compartiments gainés env. 34 x 34 mm (non destinés à des cartes)*

**4106C** 235 x 235 x 18/25 mm



**Winkelkarte für Stecker**  
Angle pad for drop stud earrings  
*Carte recourbée pour clous d'oreilles*

**5W/Wi** 35 x 35 mm



**25 flache Polyfächer**  
25 flat set-in poly compartments  
*25 compartiments poly plats*

**4152** 235 x 235 x 18/25 mm



**Erhöhte Karte für Ohringe**  
Raised pad for earrings  
*Cartouche surélevée pour B.O.*

**5W/X** 35 x 35 mm

Maßangaben: Länge x Breite x Höhe | Dimensions: Length x Width x Height | Dimensions: Longueur x Largeur x Hauteur



**16 flache Polyfächer**  
16 flat poly compartments  
*16 compartiments poly plats*

**4153** 235 x 235 x 18/25 mm



**Karte für Anhänger/Brosche**  
Pad for pendant/brooch  
*Carte pour pend./broche*

**5W** 35 x 35 mm

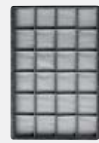

**24 flache Taftfächer**  
24 flat taffeta compartments  
*24 compartiments taffetas plats*

**4708** 235 x 156 x 18/25 mm



**Winkelkarte für Stecker**  
Angle pad for drop stud earrings  
*Carte recourbée pour clous d'oreilles*

**5W/Wi** 35 x 35 mm

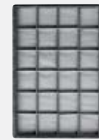

**24 ausgeschlagene Fächer ca. 34 x 34 mm (nicht für Karten)**  
24 lined compartments approx. 34 x 34 mm (not for pads)  
*24 compartiments gainés env. 34 x 34 mm (non destinés à des cartes)*

**4708C** 235 x 156 x 18/25 mm



**Erhöhte Karte für Ohringe**  
Raised pad for earrings  
*Cartouche surélevée pour B.O.*

**5W/X** 35 x 35 mm



**15 flache Polyfächer**  
15 flat poly compartments  
*15 compartiments poly plats*

**4710** 235 x 156 x 18/25 mm



**36 tiefe Taftfächer (mit Hohlraum unter Karte)**  
36 deep taffeta compartments (with recess below pad)  
*36 compartiments taffetas surélevés (avec de l'espace sous cartouches)*

**4106V** 235 x 235 x 25 mm



**Karte für Ohringe**  
Pad for drop earrings  
*Carte avec fentes pour B.O.*

**5W/D** 35 x 35 mm



**25 tiefe Polyfächer (mit Hohlraum unter Karte)**  
25 deep poly compartments (with recess below pad)  
*25 compartiments poly surélevés (avec de l'espace sous cartouches)*

**4152V** 235 x 235 x 25 mm



**Karte für Stecker**  
Pad for stud earrings  
*Carte pour clous d'oreilles*

**5W/i** 35 x 35 mm



**16 tiefe Polyfächer (mit Hohlraum unter Karte)**  
16 deep poly compartments (with recess below pad)  
*16 compartiments poly surélevés (avec de l'espace sous cartouches)*

**4153V** 235 x 235 x 25 mm



**Karte für Hängestecker**  
Pad for drop stud earrings  
*Carte pour clous d'oreilles*

**5W/i/6** 35 x 35 mm



**24 tiefe Taftfächer (mit Hohlraum unter Karte)**  
24 deep taffeta compartments (with recess below pad)  
*24 compartiments taffetas surélevés (avec de l'espace sous cartouches)*

**4708V** 235 x 156 x 25 mm



**Karte für Anhänger (Haken 765)**  
Pad for pendant (Hook 765)  
*Carte pour pend. (Crochet 765)*

**5W/HA9** 35 x 35 mm



**15 tiefe Polyfächer (mit Hohlraum unter Karte)**  
15 deep poly compartments (with recess below pad)  
*15 compartiments poly surélevés (avec de l'espace sous cartouches)*

**4710V** 235 x 156 x 25 mm



Tiefgezogene Einsätze | Vacuum-formed inserts | Inserts thermoformés

VARIO NORM



**16 Fächer (210 x 25 mm) für Kartenserie 322...**  
16 compartments (210 x 25 mm) for Pad series 322...  
*16 compartiments (210 x 25 mm) pour Carte série 322...*

**4256** 460 x 220 mm



**35 vertiefte Fächer (55 x 38 mm) für Kartenserie 302...**  
35 deep compartments (55 x 38 mm) 16 compartments (210 x 25 mm) for Pad series 302...  
*35 compartiments surélevés (55 x 38 mm) pour Carte série 302...*

**4253V** 460 x 220 mm



**33 vertiefte Fächer (55 x 38 mm) für Kartenserie 302...**  
33 deep compartments (55 x 38 mm) for Pad series 302...  
*33 compartiments surélevés (55 x 38 mm) pour carte série 302...*

**4252V** 460 x 220 mm



**44 vertiefte Fächer (45 x 35 mm) für Kartenserie 303...**  
44 deep compartments (45 x 35 mm) for Pad series 303...  
*44 compartiments surélevés (45 x 35 mm) pour Carte série 303...*

**4254V** 460 x 220 mm



**55 vertiefte Fächer (35 x 35 mm) für Kartenserie 328...**  
55 deep compartments (35 x 35 mm) for Pad series 328...  
*55 compartiments surélevés (35 x 35 mm) pour Carte série 328...*

**4258V** 460 x 220 mm



**12 vertiefte Fächer (70 x 45 mm) für Kartenserie 301...**  
12 deep compartments (70 x 45 mm) for Pad series 301 ...  
*12 compartiments surélevés (70 x 45 mm) pour Carte série 322...*

**4251XV** 220 x 220 mm



**15 vertiefte Fächer (55 x 38 mm) für Kartenserie 302...**  
15 deep compartments (55 x 38 mm) for Pad series 302 ...  
*15 compartiments surélevés (55 x 38 mm) pour Carte série 322...*

**4252XV** 220 x 220 mm



**20 vertiefte Fächer (45 x 35 mm) für Kartenserie 303...**  
20 deep compartments (45 x 35 mm) for Pad series 303 ...  
*20 compartiments surélevés (45 x 35 mm) pour Carte série 303...*

**4254XV** 220 x 220 mm



**24 vertiefte Fächer (50 x 30 mm) für Kartenserie 331...**  
24 deep compartments (50 x 30 mm) for Pad series 331 ...  
*24 compartiments surélevés (50 x 30 mm) pour Carte série 331...*

**4255XV** 220 x 220 mm



**25 vertiefte Fächer (35 x 35 mm) für Kartenserie 328...**  
25 deep compartments (35 x 35 mm) for Pad series 328 ...  
*25 compartiments surélevés (35 x 35 mm) pour Carte série 328...*

**4258XV** 220 x 220 mm

Maßangaben: Länge x Breite x Höhe | Dimensions: Length x Width x Height | Dimensions: Longueur x Largeur x Hauteur



Ringladen | Ring trays | Plateaux de bagues

VARIO NORM

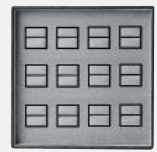

**12 Ring-Bäckchen (35 x 35 mm)**  
12 rings, large square ring containers  
12 bagues, cases carrées

**4115** 235 x 235 x 32 mm



**12 breite Ringe (bis 6 mm)**  
12 wide rings (up to 6 mm)  
12 bagues larges, jusqu'à 6 mm

**4115Z** 235 x 235 x 32 mm



**12 x 2 Ringe, Schlitz senkrecht**  
12 x 2 rings, vertical slits  
12 x 2 bagues, fentes verticales

**4115TR** 235 x 235 x 32 mm

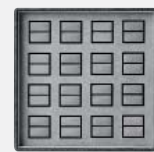

**16 Ring-Bäckchen (35 x 35 mm)**  
16 rings, large square ring containers  
12 bagues, cases carrées

**4116** 235 x 235 x 32 mm



**16 breite Ringe (bis 6mm)**  
16 wide rings (up to 6mm)  
16 bagues larges, jusqu'à 6mm

**4116Z** 235 x 235 x 32 mm



**16 x 2 Ringe, Schlitz senkrecht**  
16 x 2 rings, vertical slits  
16 x 2 bagues, fentes verticales

**4116TR** 235 x 235 x 32 mm



**12 Ring-Bäckchen (35 x 35 mm)**  
12 rings, large square ring containers  
12 bagues, cases carrées

**4721** 156 x 235 x 32 mm



**12 breite Ringe (bis 6 mm)**  
12 wide rings (upto 6 mm)  
12 bagues larges, jusqu'à 6 mm

**4721Z** 156 x 235 x 32 mm



**12 x 2 Ringe, Schlitz senkrecht**  
12 x 2 rings, vertical slits  
12 x 2 bagues, fentes verticales

**4721TR** 156 x 235 x 32 mm



**Ringwulsten (10 Ringreihen)**  
Covered sponge rolls (10 ring rows)  
Rouleaux, 10 rangées de bagues

**4117** 235 x 235 x 32 mm



**Ringwulsten (6 Ringreihen)**  
Covered sponge rolls (6 ring rows)  
Rouleaux, 6 rangées de bagues

**4717** 156 x 235 x 32 mm

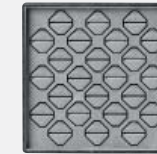

**24 Ringe, 8-Eck**  
24 rings, octagonal ring containers  
24 bagues, cases de bagues octogonales

**4129** 235 x 235 x 32 mm



**24 x 2 Ringe, 8-Eck. Schlitz diagonal**  
24 x 2 rings, octagonal ring containers,  
diagonal slits  
24 x 2 bagues, cases octogonales,  
fentes diagonales

**4129TR** 235 x 235 x 32 mm



**18 Ringe, 8-Eck (33 x 33 mm)**  
18 rings, octagonal ring containers  
(33 x 33 mm)  
18 bagues, cases de bagues octogonales  
(33 x 33 mm)

**4759** 156 x 235 x 32 mm



**18 x 2 Ringe, 8-Eck., Schlitz diagonal**  
18 x 2 rings, octagonal ring containers,  
diagonal slits  
18 x 2 bagues, cases octogonales,  
fentes diagonales

**4759TR** 156 x 235 x 32 mm



**7 herausnehmbare Rollen**  
7 removable, covered sponge rolls  
7 rouleaux amovibles

**41RR7** 235 x 235 x 32 mm



**2 x 7 herausnehmbare Rollen**  
2 x 7 removable, covered sponge rolls  
2 x 7 rouleaux amovibles

**41RR14** 235 x 235 x 32 mm



**7 herausnehmbare Rollen**  
7 removable, covered sponge rolls  
7 rouleaux amovibles

**47RR7** 235 x 235 x 32 mm



**4 herausnehmbare Wulsten**  
4 removable, covered sponge rolls  
4 rouleaux amovibles

**41WD4** 235 x 235 x 32 mm



**4 herausnehmbare Wulsten**  
4 removable, covered sponge rolls  
4 rouleaux amovibles

**47WD4** 235 x 156 x 32 mm



**15 Ringe, 8-Eck**  
15 ring containers octagonal  
15 bagues cases octogonales

**4732** 235 x 156 x 32 mm



**9 Ringe, 6-Eck**  
9 square ring containers hexagonal  
9 bagues cases hexagonales

**4747** 235 x 156 x 32 mm



**12 Ringe, 6-Eck**  
12 square ring containers hexagonal  
12 bagues cases hexagonales

**4749** 235 x 156 x 32 mm



**49 Ringe, kaschierte Einlage**  
49 rings, laminated sponge insert  
49 bagues, intérieur en mousse gainée

**4163** 235 x 235 x 32 mm



**21 Ringe, mit vertiefter Rückseite**  
21 rings, with honeycomb back  
21 bagues, avec dos creusé

**4744** 156 x 235 x 20 mm



**Lade für 4 x 3 tlg. Garnitur, 4 Ringe in Einzelbäckchen, 4 Polyfächer für Karten**  
**52 x 35 mm und 35 x 35 mm**  
Tray for 3-piece set: 4 square ring containers, 4 poly compartments for pads 52 x 35 mm and 35 x 35 mm  
plateau pour 4 sets de présentation de 3 pièces, 4 bagues dans cases individuelles, 4 compartiments plastiques pour cartes 52 x 35 mm et 35 x 35 mm

**4148** 156 x 235 x 32 mm



**Lade für 3 x 3 tlg. Garnitur, 3 Ringe in Einzelbäckchen, 3 Polyfächer für Karten**  
**52 x 35 mm und 35 x 35 mm**  
Tray for 3 Piece set: 3 square ring containers, 3 poly compartments for pads 52 x 35 mm and 35 x 35 mm  
plateau pour 3 sets de présentation de 3 pièces, 3 bagues dans cases individuelles, 3 compartiments plastiques pour cartes 52 x 35 mm et 35 x 35 mm

**4753** 156 x 235 x 32 mm



Laden für Ketten | Trays for chains | Plateaux pour chaînes

VARIO NORM



**20-er Hakenleiste (gold-/silberfarben)**  
Strip of 20 hooks (gilt/chrome)  
*Barre de 20 crochets (dorés/argentés)*

**4110** 235 x 235 x 18 mm



**20-er Hakenleiste (gold-/silberfarben), Klappe/Tasche**  
Strip of 20 hooks (gilt/chrome) flap/pocket  
*Barre de 20 crochets (dorés/argentés) rabat/poche*

**4130** 235 x 235 x 25 mm



**12-er Hakenleiste (gold-/silberfarben)**  
Strip of 12 hooks, (gilt/chrome)  
*Barre de 12 crochets (dorés/argentés)*

**4755** 156 x 235 x 18 mm



**Büste: 1 Collier**  
Raised neck form: 1 necklace  
*Buste: 1 collier*

**4156** 235 x 235 x 14 mm



**Büste: 1 Collier**  
Raised neck form: 1 necklace  
*Buste: 1 collier*

**4739** 156 x 235 x 14 mm



**Büste: Collier/Ring**  
Raised neck form: necklace/ring  
*Buste: collier/bague*

**4157** 235 x 235 x 14 mm



**Büste: Collier/Ring**  
Raised neck form: necklace/ring  
*Buste: collier/bague*

**4740** 156 x 235 x 14 mm



**Büste: Collier/Band/Ring**  
Raised neck form: necklace/bracelet/ring  
*Buste: collier/bracelet/bague*

**4159** 235 x 235 x 14 mm



**Büste: Collier/Band**  
Raised neck form: necklace/bracelet  
*Buste: collier/bracelet*

**4741** 156 x 235 x 14 mm



**Büste: Collier/Band/Ring/Stecker**  
Raised neck form: necklace/bracelet/ring/earrings  
*Buste: collier/bracelet/bague/B.O.*

**4159D1** 235 x 235 x 14 mm



**Büste: Collier/Band/Ring**  
Raised neck form: necklace/bracelet/ring  
*Buste: collier/bracelet/bague*

**4742** 156 x 235 x 14 mm



**Büste: Collier/Band/Ring/Stecker**  
Raised neck form: necklace/bracelet/ring/earrings  
*Buste: collier/bracelet/bague/B.O.*

**4742D4** 156 x 235 x 14 mm



**10 Fächer f. Ketten mit Einzelhaken (gold-/silberfarben)**  
Tray with 10 lined compartments with a metal hook each (gilt/chrome)  
*10 comp. p. chaînes munis de crochets individuels (dorés/argentés)*

**4231** 472 x 235 x 18 mm



**7 Fächer f. Ketten mit Einzelhaken (gold-/silberfarben)**  
Tray with 7 lined comp. with a metal hook each (gilt/chrome)  
*7 comp. p. chaînes munis de crochets individuels (dorés/argentés)*

**4764** 472 x 156 x 18 mm



**Für Ketten, 42-er Hakenleiste (gold-/silberfarben)**  
For chains, strip of 42 hooks (gilt/chrome)  
*P. chaînes, barre de 42 crochets sur le grand côté (dorés/argentés)*

**4233** 472 x 235 x 18 mm



**Für Ketten, 20-er Hakenleiste (gold-/silberfarben)**  
For chains, strip of 20 hooks (gilt/chrome)  
*P. chaînes, barre de 20 crochets sur le petit côté (dorés/argentés)*

**4232** 472 x 235 x 18 mm



**Für Ketten, 12-er Hakenleiste (gold-/silberfarben)**  
For chains, strip of 12 hooks (gilt/chrome)  
*pour chaînes, barre de 12 crochets sur le petit côté (dorés ou argentés)*

**4754** 472 x 156 x 18 mm



**8 Rillen ca. 16 mm, seitl. bewegliche Klappen**  
8 grooves approx. 16 mm, movable side flaps  
*8 rainures d'environ 16 mm, rabats repliables sur les côtés*

**4236D8** 472 x 235 x 18 mm



**12 Rillen ca. 8 mm, seitl. bewegliche Klappen**  
12 grooves approx. 8 mm, movable side flaps  
*12 rainures d'environ 8 mm, rabats repliables sur les côtés*

**4237** 472 x 235 x 18 mm

Maßangaben: Länge x Breite x Höhe | Dimensions: Length x Width x Height | Dimensions: Longueur x Largeur x Hauteur

Laden für Uhren & Armbreife | Trays for watches & bangles | Plateaux pour montres & jongs **VARIO NORM**



**10 Uhrspangen SP4 (incl.)**  
10 watch supports SP4 (inclusive)  
10 supports montre SP4 (inclus)

**4131** 235 x 235 x 50 mm



**6 Uhrspangen SP4 (incl.)**  
6 watch supports SP4 (inclusive)  
6 supports montre SP4 (inclus)

**4766** 156 x 235 x 50 mm



**Überzogene Spange (Federstahl)**  
Covered metal watch support  
Support montre gainé

**SP4** B: 30 mm



**Wulsten, 9 Armreifreihen**  
Continuous covered sponge rolls for  
9 rows bangles  
Rouleaux continus pour jongs fins  
(9 rangées)

**4136** 235 x 235 x 75 mm



**Wulsten, 5 Armreifreihen**  
Continuous covered sponge rolls for  
5 rows bangles  
Rouleaux continus pour jongs fins  
(5 rangées)

**4743** 156 x 235 x 75 mm



**Seitliche Führung für Trennstäbe (zzgl.)**  
Guiding supports for dividers (not incl.)  
Conduits sur les côtés pour séparations

**4141** 235 x 235 x 18 mm



**Seitliche Führung für Trennstäbe (zzgl.)**  
Guiding supports for dividers  
Glissière latérale pour séparations

**4714** 235 x 156 x 18 mm



**Zzgl. Trennstäbe**  
Plus dividers  
Séparations amovibles, à commander séparément

**4141T**



**4 ausgeschlagene Längsfächer (53 x 458 mm), Stege hoch**  
4 lined compartments (53 x 458 mm), high dividers  
4 comp. en long. (53 x 458 mm), séparations hautes

**4247** 472 x 235 x 50 mm



**15 Uhrenspangen SP6 (incl.)**  
15 watch supports SP6 (included)  
15 supports montre SP6 (inclus)

**4133** 235 x 235 x 75 mm



**Überzogene Spange (Federstahl)**  
Covered metal watch support  
Support montre gainé

**SP6** B: 32 mm

Maßangaben: Länge x Breite x Höhe | Dimensions: Length x Width x Height | Dimensions: Longueur x Largeur x Hauteur

Zubehör | Accessories | Accessoires

**VARIO NORM**



**ALU-Schild für Lade (gold-/silberfarben)**  
Alu label plate for trays (gilt/chrome)  
Plaque en ALU (dorée/argentée) pour plateau

**704A**

**Maße Alu-Schild/dim. alu label plate/dim. plaque en alu:**

10 x 26 mm

**Maße Etikett/dim. alu label/dim. étiquette:**

8 x 16 mm



**Klettband-Gurte, schwarz**  
Velcro strap in black  
Courroie velcro noire

**7025/100** 1000 mm

**7025/130** 1300 mm

**7025/150** 1500 mm

**7025/180** 1800 mm



**Etikettenrahmen für Laden (gold-/silberfarben)**  
Label frame for trays (gilt/chrome)

Label frame for trays (gilt/chrome)

Cadre étiquette (doré/argenté) pour plateau

**704E**

**Maße Etikettenrahmen/dim. label frame/dim. cadre étiquette:**

10,1 x 38 mm

**Maße Etikett/dim. alu label/dim. étiquette:**

9,9 x 26 mm

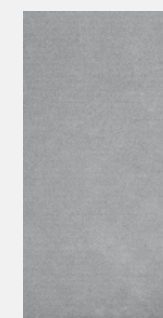

**Deckchen, 3 mm schaumstoffgepolstert**  
Top cover, 3 mm foam-padded cushion  
Napperon rembourré de 3 mm de mousse

**42020** 460 x 220 mm

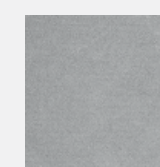

**Deckchen, 3 mm schaumstoffgepolstert**  
Top cover, 3 mm foam-padded cushion  
Napperon rembourré de 3 mm de mousse

**41020** 223 x 223 mm









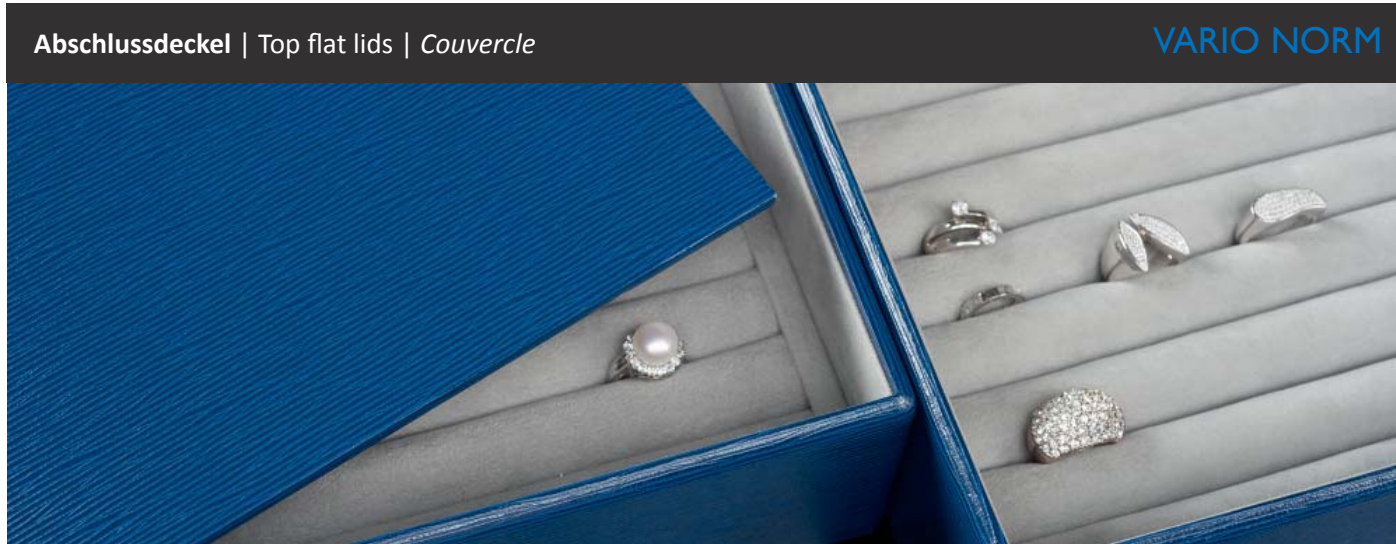

**Deckchen, 3 mm schaumstoffgepolstert**  
Top cover, 3 mm foam-padded cushion  
Napperon rembourré de 3 mm de mousse

**47020** 221 x 143 mm

Maßangaben: Länge x Breite x Höhe | Dimensions: Length x Width x Height | Dimensions: Longueur x Largeur x Hauteur



**Abschlussdeckel | Top flat lids | Couvercle** **VARIO NORM**

	<b>Abschlussdeckel, flach</b> Flat top lid <i>Couvercle, plat</i>	<b>42001</b> 472 x 235 x 5 mm
	<b>Abschlussdeckel, flach</b> Flat top lid <i>Couvercle, plat</i>	<b>41001</b> 235 x 235 x 5 mm
	<b>Abschlussdeckel für Büstenladen mit runder Büste</b> Top lid for bust trays with a round raised neck form <i>Couvercle pour plateau buste à buste rond</i>	<b>41002</b> H: 45 mm
	<b>Abschlussdeckel für Büstenladen mit ovaler Büste</b> Top lid for bust trays with an oval raised neck form <i>Couvercle pour plateau buste à buste oval</i>	<b>41002/1</b> H: 45 mm
	<b>Abschlussdeckel, flach</b> Flat top lid <i>Couvercle, plat</i>	<b>47001</b> 235 x 156 x 5 mm
	<b>Abschlussdeckel für Büstenladen mit runder Büste</b> Top lid for bust trays with a round raised neck form <i>Couvercle pour plateau buste à buste rond</i>	<b>47002</b> 235 x 156 x 5 mm
	<b>Abschlussdeckel für Büstenladen mit ovaler Büste</b> Top lid for bust trays with an oval raised neck form <i>Couvercle pour plateau buste à buste oval</i>	<b>47002/1</b> 235 x 156 x 5 mm
	<b>Abschlussdeckel für Ringlade mit vertiefter Rückseite</b> Top lid for ring trays with honeycomb backs <i>Couvercle pour plateaux bagues à dos encastré</i>	<b>47002R</b> 235 x 156 x 5 mm
	<b>Abschlussdeckel für Ringlade mit vertiefter Rückseite</b> Top lid for ring trays with honeycomb back <i>Couvercle pour plateau bagues à dos creusé</i>	<b>41005</b> 235 x 156 x 5 mm

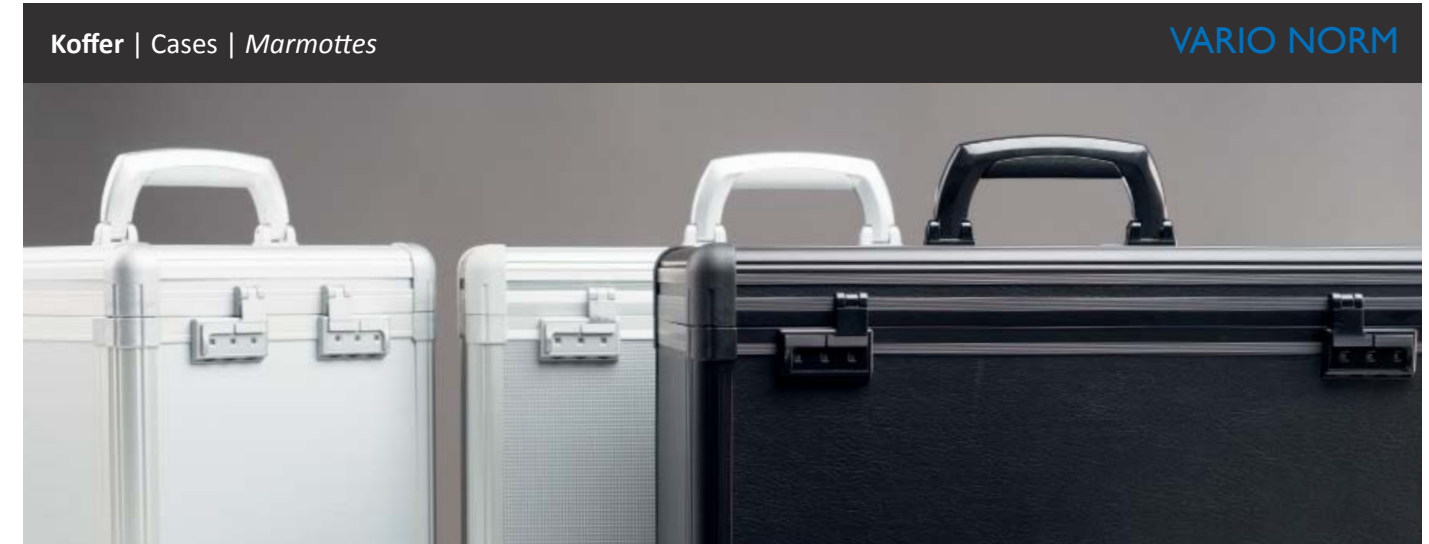

**Koffer | Cases | Marmottes** **VARIO NORM**

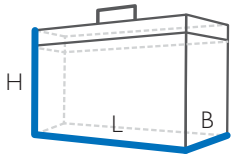
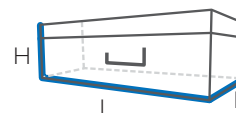
<b>1. Modell: Koffer, stehend</b>	<b>2. Modell: Koffer, liegend</b>	<b>1. Modell: Koffer, stehend</b>   Design: upright case   <i>Modèle: format vertical</i>
		<b>2. Modell: Koffer, liegend</b>   Design: flat case   <i>Modèle: format horizontal</i>
<b>Maßangaben Länge x Breite x Höhe</b> Dimensions: Length x Width x Height <i>Dimensions marmotte hauteur: Longueur x Largeur x Hauteur</i>		

**DER KLASSIKER - FÜR ALLE DREI LADENGRÖSSEN**



**Holzkofer, stehend, mit Ausfallklappe, Alu-Kantenprofil und Zahlenschlösser, unterschiedliche Oberflächen wählbar**  
Upright wooden case with forward opening flap, aluminum edge profile and combination locks, various outer finishes available  
*Marmotte verticale avec rabat amovible, profilés en aluminium et serrure de combinaison, différentes finitions extérieures possibles*

**4000/61**  
Dim. innen/int.: 480 x 240 x 375 mm  
Dim. außen/ext.: 505 x 280 x 430 mm



**Holzkofer, liegend, mit Ausfallklappe, Alu-Kantenprofil und Zahlenschlösser, unterschiedliche Oberflächen wählbar**  
Flat collection case, wooden frame with forward opening flap, aluminium edge profile and combination locks, various outer finishes available  
*Marmotte couchée avec rabat amovible, profilés en aluminium et serrure de combinaison, différentes finitions extérieures possibles*

**4001/61**  
Dim. innen/int.: 480 x 240 x 140 mm  
Dim. außen/ext.: 505 x 290 x 165 mm

**DER PRAKTISCHE  
FÜR ALLE DREI LADENGRÖSSEN**

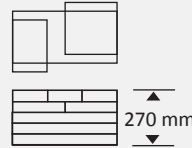

**Rollenkoffer mit Laptoptasche**

Wheeled case with laptop bag  
*Marmotte avec sacoché d'ordinateur portable*

**4027R**

Dim. innen/int.: 485 x 270 x 370 mm  
Dim. außen/ext.: 520 x 365 x 450 mm

**DER QUADRATISCHE -  
FÜR LADEN DER 41ER SERIE**



**Holzkofer, stehend, mit Ausfallklappe, Alu-Kantenprofil und Zahlenschlösser, unterschiedliche Oberflächen wählbar**

Upright wooden case, with forward opening flap, aluminum edge profile and combination locks, various outer finishes available  
*Marmotte verticale avec rabat amovible, profilés en aluminium et serrure de combinaison, différentes finitions extérieures possibles*

**4004/61**

Dim. innen/int.: 240 x 240 x 375 mm  
Dim. außen/ext.: 263 x 275 x 430 mm



**Stülphülle schwarz**  
Pull on case cover, black  
*Housse noire*

**4006** Serie 4000



**Überzug schwarz mit Reissverschluss**  
Zip-up case cover, black  
*Housse noire à fermeture éclair*

**4007** Serie 4000



**Stülphülle schwarz**  
Pull on case cover, black  
*Housse noire*

**4006/1** Serie 4001



**Überzug schwarz mit Reissverschluss, Ecken wattiert**  
Zip-up case cover, black with padded corners  
*Housse noire à fermeture éclair, rembourrée dans les coins*

**4007P** Serie 4000



**Stapelhilfe, 30 mm Schaum schwarz**  
Stacking aid, 30mm black foam  
*Aide à l'empilage mousse noire 30 mm*

**4000ST** Serie 4000  
**4750ST** Serie 4750

**DER SCHLANKE  
FÜR LADEN DER 47ER SERIE**



**Holzkofer, stehend, mit Ausfallklappe, Alu-Kantenprofil und Zahlenschlösser, unterschiedliche Oberflächen wählbar**

Upright wooden case, with forward opening flap, aluminum edge profile and combination locks, various outer finishes available  
*Marmotte verticale avec rabat amovible, profilés en aluminium et serrure de combinaison, différentes finitions extérieures possibles*

**4750/61**

Dim. innen/int.: 480 x 165 x 375 mm  
Dim. außen/ext.: 505 x 200 x 430 mm

Kettenkoffer | Cases for chains | Valise pour chaînes/colliers

VARIO NORM



## UNSERE SPEZIALISTEN FÜR SCHMUCK-KETTEN



**Holzkoffer, stehend, Alu-Kantenprofil und Zahlenschlösser, zzgl. 5 Laden 4014, unterschiedliche Oberflächen wählbar**  
Upright wooden case, aluminum edge profile and combination locks, plus 5 trays 4014, various outer finishes available  
*Marmotte verticale avec rabat amovible, profilés en aluminium et serrure de combinaison, différentes finitions extérieures possibles*

**4010B/61** 440 x 160 x 365 mm (Dim. außen/ext.)



**Holzkoffer, stehend, mit Ausfallklappe, Alu-Kantenprofil und Zahlenschlösser, zzgl. 10 Tücher, unterschiedliche Oberflächen wählbar**  
Upright wooden case, with forward opening flap, aluminum edge profile and combination locks, for 10 drapes (not incl.), various outer finishes available  
*Marmotte verticale avec rabat amovible, profilés en aluminium et serrure de combinaison, p.10 drapeaux, différentes finitions extérieures possibles*

**4015/61** 470 x 235 x 425 mm (Dim. außen/ext.)



**Lade mit 12 Fächer, kleine Hakenleiste (gold/silber), Tasche**  
Drawer with 12 comp., strip of small hooks (gilt/chrome), pocket  
*Plateau à 12 comp., barre de petits crochets (dorés/argentés), poche*

**4014D1** 290 x 415 x 18 mm



**Lade, große 28-er Hakenleiste (gold/silber), Tasche**  
Drawer, strip of large hooks (gilt/chrome), pocket  
*Plateau, barre de gros crochets (dorés/argentés), poche*

**4014D2** 290 x 415 x 18 mm



**Kettentuch mit 13 Druckknöpfen**  
Hanging drapes with 13 press-studs  
*Drapeau de chaînes muni de 13 boutons-pressions*

**4017C (Pic)** 460 x 445 x 15 mm  
**4017D (Deluxe)** 460 x 445 x 15 mm

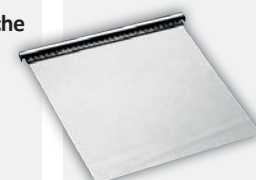

**Kettentuch mit Hakenleiste, 30 Haken, (gold/silber)**  
Hanging drapes with a strip of 30 hooks (gilt/chrome)  
*Drapeau de chaînes muni d'une barre de 30 crochets (dorés/argentés)*

**4018C (Pic)** 460 x 445 x 15 mm  
**4018D (Deluxe)** 460 x 445 x 15 mm



INTERIOR DESIGN VARIO NORM

SQUARE SHAPE

TRAYS PAINTABLE IN ALL RAL-COLOURS

1 TRAY SIZE

## SERIE VARIO STYLE

Scharf gezeichnete Konturen, verstärkt durch das edle Finish der Hochglanzlackierung - das ist die neue Optik der Design-Serie von Kling. Das innovative Produktionsverfahren für diese Serie ermöglicht nicht nur eine unbestechliche Optik, sondern auch ein geringes Gewicht und eine hohe Präzision. Die passenden Materialien für die Innenausstattung zeigen wir Ihnen gerne. Mit dieser Ladenserie sind Sie in jedem Fall am Puls der Zeit und hinterlassen bei Ihren Kunden einen extravaganen Eindruck.

Sharp contours reinforced by the classy high-gloss finish are key elements of the Vario Style range from Kling. The innovative production process for this range allows not just a high quality appearance, but also low product weight and high accuracy. We will be happy to show you suitable materials for the interior. With this range of trays you will have your fingers on the pulse in every situation and leave an extravagant impression on your customers.

*Des contours aux lignes précises, mis en valeur par la finition de qualité de la laque ultra brillante - voila la nouvelle présentation de la série design de Kling. Grâce au procédé de fabrication innovant de cette série, le produit revêt un aspect parfait mais est aussi d'un faible poids et d'une grande précision. Nous nous ferons un plaisir de vous présenter les matériaux adéquats de l'équipement intérieur. Avec cette série de plateaux, vous êtes toujours dans l'air du temps et laissez après de vos clients une impression inoubliable.*

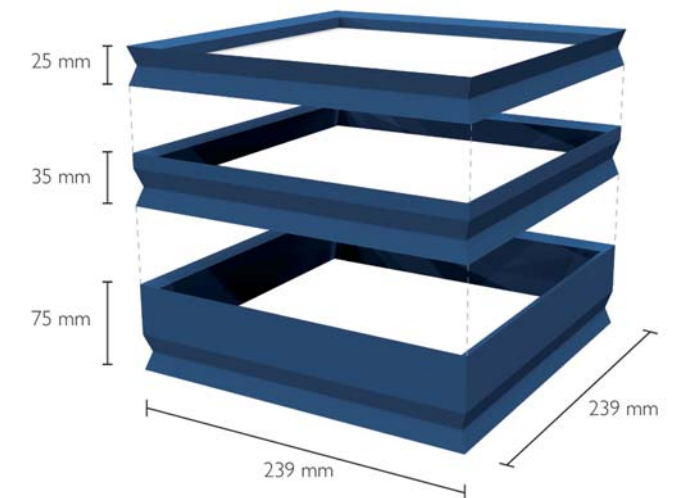



## VARIO STYLE



Lade, passend für Einrichtungen der Vario Norm Serie beginnend mit der Nummer 41.. - siehe Seite 56 - 78

Tray suitable for interiors of Vario Norm series starting with the number 41.. - See page 56 - 78

Plateaux, adaptables aux intérieurs de la série Vario Norm ref. 41 .. - Voir pages 56 - 78

L41.. 239 x 239 x 25 mm



Lade, passend für Einrichtungen der Vario Norm Serie beginnend mit der Nummer 41.. - siehe Seite 56 - 78

Tray suitable for interiors of Vario Norm series starting with the number 41.. - See page 56 - 78

Plateaux, adaptables aux intérieurs de la série Vario Norm ref. 41 .. - Voir pages 56 - 78

L41.. 239 x 239 x 35 mm



Lade, passend für Einrichtungen der Vario Norm Serie beginnend mit der Nummer 41.. - siehe Seite 56 - 78

Tray suitable for interiors of Vario Norm series starting with the number 41.. - See page 56 - 78

Plateaux, adaptables aux intérieurs de la série Vario Norm ref. 41 .. - Voir pages 56 - 78

L41.. 239 x 239 x 75 mm



GENUINE LEATHER CASE

JEWELLERY &  
WATCH TRAYS

2 TRAY SIZES

## SERIE VARIO LUX

Vario Lux besticht durch seine Handlichkeit. Durch kleinere Präsentationsflächen kommt jedes einzelne Schmuckstück besser zur Geltung und erhält dadurch mehr Aufmerksamkeit. Die Kollektion kann durch die Zusammenstellung verschiedenster Einsätze und Bezüge perfekt auf Ihre Bedürfnisse abgestimmt werden.

The Vario Lux series impresses with its versatility. With smaller presentation systems, each jewellery piece is shown to maximum advantage. The collection can be perfectly tailored to your needs by combining different inserts and coverings.

Vario Lux impressionne par sa maniabilité. Les pièces individuelles ressortent mieux sur de plus petites surfaces de présentation et attirent ainsi davantage l'attention. La personnalisation de la collection repose sur une composition individualisée de coussins/cartes et la diversité des gaineries.

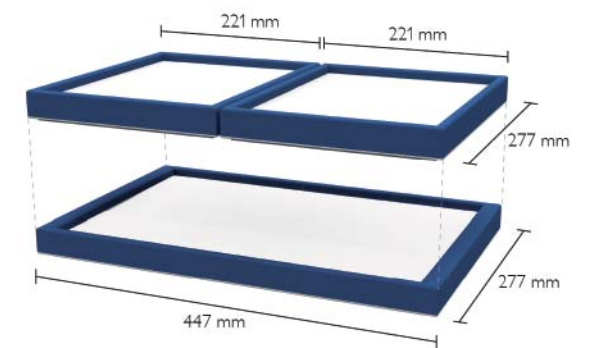

## DRUCK AUF ANFRAGE

PRINT ON REQUEST  
IMPRESSION SUR DEMANDE



Maßangaben: Länge x Breite x Höhe | Dimensions: Length x Width x Height | Dimensions: Longueur x Largeur x Hauteur



**1 flaches Taftfach**  
1 flat taffeta compartment  
1 compartiment taffeta plat

**6701A** 277 x 221 x 18/25 mm

**1 ausgeschlagenes Fach ca. 261 x 206 mm (nicht für Karten)**

1 lined compartment approx. 261 x 206 mm (not for pads)  
1 compartiment gainé env. 261 x 206 mm (non destinés à des cartes)

**6701C** 277 x 221 x 18/25 mm

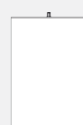

**Platte mit 1 Ausheber**  
Pad with 1 tab  
carte gainée, rembourrée, avec languette

**5UX** 262 x 207 mm

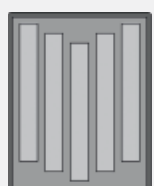

**5 flache Polyfächer**  
5 flat poly compartments  
5 compartiments poly plats

**6751/18** 277 x 221 x 18 mm



**6 flache Polyfächer**  
6 flat poly compartments  
6 compartiments poly plats

**6751P6** 277 x 221 x 18 mm



**Karte mit 2 Gummis**  
Pad with 2 elastics  
Carte rembourré gainé, munie de 2 élastiques

**5F** 210 x 25 mm

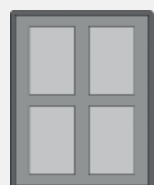

**4 flache Polyfächer**  
4 flat poly compartments  
4 compartiments poly plats

**6702** 277 x 221 x 18/25 mm



**Karte für Anhänger, hoch**  
Pad for pendant, portrait  
Carte pour pend., verticale

**5H/H** 105 x 70 mm



**Karte für Broschen, quer**  
Pad for brooch, landscape  
Carte pour broche, horizontale

**5H/Q** 70 x 105 mm



**Karte für Kette mit Anhänger**  
Pad for chain with pendant  
Carte pour chaîne avec pend.

**5H/TH** 105 x 70 mm



**5H/TQ** 70 x 105 mm



**Winkelkarte für Ohrschmuck/Creolen**  
Angle Pad for drop stud earrings/hoops  
Carte recourbée pour dormeuses/B.O./Créoles

**5H/WiH** 105 x 70 mm



**5H/WiQ** 70 x 105 mm



**Erhöhte Karte für Ohringe**  
Raised pad for earrings  
Cartouche surélevée pour B.O.

**5H/Y** 105 x 70 mm



**Karte für Clips**  
Pad for clips  
Carte pour clips

**5H/B2Q** 70 x 105 mm



**6 flache Polyfächer**  
6 flat poly compartments  
6 compartiments poly plats

**6756** 277 x 221 x 18/25 mm



**6 tiefe Polyfächer**  
6 deep poly compartments  
6 compartiments poly surélevés

**6756V** 277 x 221 x 25 mm



**Karte für Anhänger/Brosche**  
Pad for pendant/brooch  
Carte pour pend./broche

**5L** 70 x 70 mm



**Erhöhte Karte für Ohringe**  
Raised pad for earrings  
Cartouche surélevée pour B.O.

**5L/Y** 70 x 70 mm



**Winkelkarte für Ohrschmuck/Creolen**  
Angle Pad for drop stud earrings/hoops/creoles  
Carte recourbée pour dormeuses/B.O./Créoles

**5L/Wi** 70 x 70 mm



**Karte für Clips**  
Pad for clips  
Carte pour clips

**5L/B3** 70 x 70 mm



**Karte für Ketten mit Anhänger**  
Pad for chain with pendant  
Carte pour chaîne avec pend

**5L/T** 70 x 70 mm



**8 flache Polyfächer**  
8 flat poly compartments  
8 compartiments poly plats

**6755** 277 x 221 x 18/25 mm



**Karte für Anhänger, hoch**  
Pad for pendant, portrait  
Carte pour pend., verticale

**50/H** 70 x 52 mm



**Karte für Broschen, quer**  
Pad for brooch, landscape  
Carte pour broche, horizontale

**50/Q** 52 x 70 mm



**Winkelkarte für Ohrschmuck/Creolen**  
Angle pad for drop stud earrings/hoops/creoles  
Carte recourbée pour dormeuses/B.O./Créoles

**50/WiH** 70 x 52 mm



**50/WiQ** 52 x 70 mm



**Erhöhte Karte für Ohringe**  
Raised pad for earrings  
Cartouche surélevée pour B.O.

**50/Y** 70 x 52 mm

Maßangaben: Länge x Breite x Höhe | Dimensions: Length x Width x Height | Dimensions: Longueur x Largeur x Hauteur



**8 tiefe Polyfächer**  
8 deep poly compartments  
*8 compartiments poly surélevés*

**6755V** 277 x 221 x 25 mm

**Karte für Stecker**  
Pad for drop stud earrings  
*Carte pour dormeuses*



**50/iH** 70 x 52 mm



**50/iQ/M** 52 x 70 mm

**Karte für Kette mit Anhänger**  
Pad for chain with pendant  
*Carte pour chaîne avec pend.*



**50/TH** 70 x 52 mm



**50/TQ** 52 x 70 mm



**Karte für Manschettenknöpfe**  
Pad for cufflinks  
*Carte pour boutons de manchettes*

**50/A4** 52 x 70 mm



**Karte für Clips**  
Pad for clips  
*Carte pour clips*

**50/B2Q** 52 x 70 mm



**Karte für Creolen + Klammer 718**  
Pad for creole earrings + clip 718  
*Carte pour créoles + clip 718*

**50/C2/Q** 52 x 70 mm



**Karte für Ohringe**  
Pad for drop earrings  
*Carte pour B.O.*

**50/DH** 70 x 52 mm



**15 flache Polyfächer**  
15 flat poly compartments  
*15 compartiments poly plats*

**6754** 277 x 221 x 18/25 mm



**Karte für Anhänger, hoch**  
Pad for pendant, portrait  
*Carte pour pend., verticale*

**5S/H** 52 x 35 mm



**Karte für Broschen, quer**  
Pad for brooch, landscape  
*Carte pour broche, horizontale*

**5S/Q** 35 x 52 mm

**Winkelkarte für Ohrschmuck/Creolen**  
Angle pad for drop stud earrings/hoops  
*Carte recourbée pour dormeuses/B.O./Créoles*



**5S/WiH** 52 x 35 mm



**5S/WiQ** 35 x 52 mm



**Erhöhte Karte für Ohringe**  
Raised pad for earrings  
*Cartouche surélevée pour B.O.*

**5S/V** 52 x 35 mm

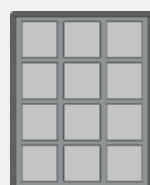

**12 flache Polyfächer**  
12 flat poly compartments  
*12 compartiments poly plats*

**6709** 277 x 221 x 18/25 mm



**Karte für Anhänger/Brosche**  
Pad for pendant/brooch  
*Carte pour pend./broche*

**5I** 52 x 52 mm



**Winkelkarte für Ohrschmuck/Creolen**  
Angle Pad for drop stud earrings/hoops  
*Carte recourbée pour dormeuses/B.O./Créoles*

**5I/Wi** 52 x 52 mm



**Erhöhte Karte für Ohringe**  
Raised Pad for earrings  
*Cartouche surélevée pour B.O.*

**5I/Y** 52 x 52 mm

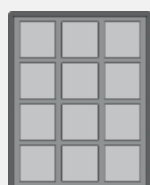

**12 tiefe Polyfächer (mit Hohlraum unter Karte)**  
12 deep poly compartments  
(with recess below pad)  
*12 compartiments poly surélevés (avec de l'espace sous cartouches)*

**6709V** 277 x 221 x 25 mm



**Karte für Kette mit Anhänger**  
Pad for chain with pendant  
*Carte pour chaîne avec pend.*

**5I/T** 52 x 52 mm



**Karte für Clips**  
Pad for clips  
*Carte pour clips*

**5I/B2** 52 x 52 mm



**Karte mit Clip-Tasche (Vorderseite)**  
Pad with front pocket for clips  
*Carte avec poche clips sur le devant*

**5I/CT** 52 x 52 mm



**15 tiefe Polyfächer**  
15 deep poly compartments  
*15 compartiments poly surélevés*

**6754V** 277 x 221 x 25 mm



**Karte für Ketten mit Anhänger**  
Pad for chain with pendant  
*Carte pour chaîne avec pend*

**5S/TH** 52 x 35 mm



**Karte für Anhänger (Haken 765)**  
Pad for pendant (Hook 765)  
*Carte pour pend. (Crochet 765)*

**5S/HA9** 52 x 35 mm



**Clip-Tasche (Vorderseite)**  
With front pocket for clips  
*Poche clips sur le devant*

**5S/CT** 52 x 35 mm



**Karte für Manschettenknöpfe**  
Pad for cufflinks  
*Carte pour boutons de manchettes*

**5S/A4** 35 x 52 mm



**Karte für Clips**  
Pad for clips  
*Carte pour clips*

**5S/B2Q** 35 x 52 mm



**Karte für Creolen + Klammer 718**  
Pad for creole earrings + clip 718  
*Carte pour créoles + clip 718*

**5S/C2/Q** 35 x 52 mm



**Karte für Ohringe**  
Pad for drop earrings  
*Carte pour B.O.*

**5S/DH** 52 x 35 mm

**Karte für Stecker**  
Pad for drop stud earrings  
*Carte pour dormeuses*



**5S/iH** 52 x 35 mm



**5S/iQ/M** 35 x 52 mm

Maßangaben: Länge x Breite x Höhe | Dimensions: Length x Width x Height | Dimensions: Longueur x Largeur x Hauteur

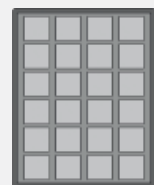

**24 flache Polyfächer**  
24 flat poly compartments  
24 compartiments poly plats

**6752** 277 x 221 x 18/25 mm

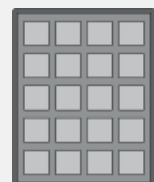

**20 flache Polyfächer**  
20 flat poly compartments  
20 compartiments poly plats

**6753** 277 x 221 x 18/25 mm

 **Karte für Anhänger/Brosche**  
Pad for pendant/brooch  
Carte pour pend./broche

**5W** 35 x 35 mm

 **Winkelkarte für Ohrschmuck/Creolen**  
Angle Pad for drop stud earrings/hoops  
Carte recourbée pour dormeuses/B.O./Créoles

**5W/Wi** 35 x 35 mm

 **Erhöhte Karte für Ohringe**  
Raised Pad for earrings  
Cartouche surélevée pour B.O.

**5W/X** 35 x 35 mm

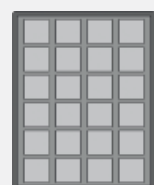

**24 tiefe Polyfächer**  
24 deep poly compartments  
24 compartiments poly surélevés

**6752V** 277 x 221 x 25 mm

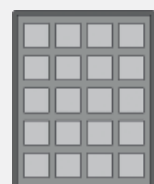

**20 tiefe Polyfächer**  
20 deep poly compartments  
20 compartiments poly surélevés

**6753V** 277 x 221 x 25 mm

 **Karte für Ohringe**  
pad for drop earrings  
Carte pour B.O.

**5W/D** 35 x 35 mm

 **Karte für Stecker**  
Pad for stud earrings  
Carte pour clous d'oreilles

**5W/i** 35 x 35 mm

 **Karte für Hängestecker**  
Pad for drop stud earrings  
Carte pour dormeuses

**5W/i/6** 35 x 35 mm

 **Karte für Anhänger (Haken 765)**  
Pad for pendant (Hook 765)  
Carte pour pend. (Crochet 765)

**5W/HA9** 35 x 35 mm



**18-er Hakenleiste (gold-/silberfarben), Klappe/Tasche**  
Strip of 18 hooks (gilt/chrome) flap/pocket  
Barre de 18 crochets (dorés/argentés), rabat/poche

**6730** 277 x 221 x 25 mm



**Seitliche Führung für Trennstäbe (zzgl.)**  
Guiding supports for dividers  
Glissière latérale pour séparations

**6741** 277 x 221 x 25 mm

**Zzgl. Trennstäbe**  
Plus dividers  
Séparations amovibles, à commander séparément

**6741T**

Ringladen | Ring trays | Plateaux de bagues

VARIO LUX



**15 Ring-Bäckchen (35 x 35 mm)**  
15 rings, square ring containers (35 x 35 mm)  
15 bagues, cases carrées (35 x 35 mm)

**6715** 277 x 221 x 32 mm



**15 breite Ringe (bis 6 mm)**  
15 wide rings (up to 6 mm)  
15 bagues larges, jusqu'à 6 mm

**6715Z** 277 x 221 x 32 mm



**15 x 2 Ringe, Schlitze senkrecht**  
15 x 2 rings, vertical slits  
15 x 2 bagues, fentes verticales

**6715TR** 277 x 221 x 32 mm



**20 Ring-Bäckchen (35 x 35 mm)**  
20 rings, square ring containers (35 x 35 mm)  
20 bagues, cases carrées (35 x 35 mm)

**6716** 277 x 221 x 32 mm



**20 breite Ringe (bis 6 mm)**  
20 wide rings (up to 6 mm)  
20 bagues larges, jusqu'à 6 mm

**6716Z** 277 x 221 x 32 mm



**20 x 2 Ringe, Schlitze senkrecht**  
20 x 2 rings, vertical slits  
20 x 2 bagues, fentes verticales

**6716TR** 277 x 221 x 32 mm



**17 Ringe, 8-Eck**  
17 rings, octagonal ring containers  
17 bagues, cases de bagues octogonales

**6734** 277 x 221 x 32 mm



**17 x 2 Ringe, 8-Eck**  
17 x 2 rings, octagonal ring containers  
17 x 2 bagues, cases de bagues octogonales

**6734TR** 277 x 221 x 32 mm



**Ringwulsten (9 Ringreihen)**  
Cont. covered sponge rolls (9 ring rows)  
Rouleaux, 9 rangées de bagues

**6717Q** 277 x 221 x 32 mm



**6 herausnehmbare Rollen für Ringe**  
6 removable covered foam rolls for rings  
6 rouleaux amovibles pour bagues

**67RR6** 277 x 221 x 32 mm

Maßangaben: Länge x Breite x Höhe | Dimensions: Length x Width x Height | Dimensions: Longueur x Largeur x Hauteur



**Leer, innen wattiert (ca. 432 x 262 mm)**  
Empty, padded (approx. 432 x 262 mm)  
*Vide, fond gainé rembourré (environ 432 x 262 mm)*

**4801** 447 x 277 x 18 mm

**Leer, innen wattiert (ca. 262 x 205 mm)**  
Empty, padded (approx. 262 x 205 mm)  
*Vide, fond gainé rembourré (environ 262 x 205 mm)*

**4801X** 277 x 221 x 18 mm

**10 ausgeschlagene Fächer (ca. 39 / 259 mm)**  
10 lined compartments (approx. 39 / 259 mm)  
*10 compartiments gainés (environ 39 / 259 mm)*

**4807** 447 x 277 x 18 mm

**5 ausgeschlagene Fächer (ca. 259 / 38 mm)**  
5 lined compartments (approx. 259 / 38 mm)  
*5 compartiments gainés (environ 259 / 38 mm)*

**4807X** 277 x 221 x 18 mm

**3 ausgeschlagene Fächer (ca. 259 / 59 mm)**  
3 lined compartments (approx. 259 / 59 mm)  
*3 compartiments gainés (environ 259 / 59 mm)*

**4807X3** 277 x 221 x 18 mm

**4 ausgeschlagene Fächer (ca. 259 / 48 mm)**  
4 lined compartments (approx. 259 / 48 mm)  
*4 compartiments gainés (environ 259 / 48 mm)*

**4807X4** 277 x 221 x 18 mm

**Inkl. 20 Spangen SP4**  
Incl. 20 watch supports SP4  
*20 supports de montres SP4 inclus*

**4804** 447 x 277 x 50 mm

**Inkl. 10 Spangen SP4**  
Incl. 10 watch supports SP4  
*10 supports de montres SP4 inclus*

**4804X10** 277 x 221 x 50 mm

**Uhrspange (überzogener Federstahl)**  
Covered metal watch support  
*supports gainés pour montres*

**SP4** 30 mm

**9 ausgeschlagene Fächer (ca. 25 / 205 mm)**  
9 lined compartments (approx. 25 / 205 mm each)  
*9 compartiments gainés (environ 25 x 205 mm)*

**4806X** 277 x 221 x 18 mm

**8 ausgeschlagene Fächer 52 x 261 mm**  
8 lined compartments 52 x 261 mm  
*8 compartiments gainés 52 x 261 mm*

**48C8/18** 447 x 277 x 18 mm

**9 ausgeschlagene Fächer 46 x 261 mm**  
9 lined compartments 46 x 261 mm  
*9 compartiments gainés 46 x 261 mm*

**48C9/18** 447 x 277 x 18 mm

**9 ausgeschlagene Fächer für Taschenuhren ca. 85 x 60 mm**  
9 lined compartments for pocket watches approx. 85 x 60 mm each  
*9 compartiments gainés pour montres de poche environ 85 x 60 mm*

**4810X9/A** 277 x 221 x 25 mm

**4 Fächer für gepolsterte Spangen 52 mm breit**  
4 compartments for watch supports 52 mm in width  
*4 compartiments pour coussins rembourrés larg.: 52 mm*

**4833X3** 277 x 221 x 60 mm

**6 Fächer für gepolsterte Spangen 52 mm breit**  
6 compartments for watch supports 52 mm in width  
*6 compartiments pour coussins rembourrés larg.: 52 mm*

**48U6XA** 277 x 221 x 60 mm

**8 Fächer für gepolsterte Spangen 52 mm breit**  
8 compartments for watch supports 52 mm in width  
*8 compartiments pour coussins rembourrés larg.: 52 mm*

**48U8X** 277 x 221 x 60 mm

**Stark wattierte Uhrspange DAU**  
Padded watch supports for ladies' watches  
*Coussin très rembourré pour montres Dames*

**SP19D/50** 65x 52 x 35 mm

**Stark wattierte Uhrspange HAU**  
Padded watch supports for gents' watches  
*Coussin très rembourré pour montres Hommes*

**SP19H/50** 83x 52 x 35 mm

**Stark wattierte Uhrspange HAU**  
Padded watch supports for gents' watches  
*Coussin très rembourré pour montres Hommes*

**SP19G/50** 83x 52 x 43 mm

**Reduktionstück für Damen-Spangen**  
Insert to reduce compartment for ladies' watch supports  
*Pièce de réduction pour coussin pour montres Dames*

**SP19V/50**

**12 Fächer für gepolsterte Spangen ca. 30 mm breit**  
12 compartments for padded watch supports width: 30 mm  
*12 compartiments pour coussins pour montres larg.: 30 mm*

**48U12X** 277 x 221 x 60 mm

**Stark wattierte Uhrspange DAU**  
Padded watch supports for ladies' watches  
*Coussin très rembourré pour montres Dames*

**SP19D/30** 65 x 32 x 35 mm

**Stark wattierte Uhrspange HAU**  
Padded watch supports for gents' watches  
*Coussin très rembourré pour montres Hommes*

**SP19H/30** 83 x 32 x 35 mm

**10 Fächer für gepolsterte Spangen ca. 42 mm breit**  
10 compartments for padded watch supports width: 42 mm  
*10 compartiments pour coussins pour montres larg.: 42 mm*

**48U10X** 277 x 221 x 60 mm

**Stark wattierte Uhrspange DAU**  
Padded watch supports for ladies' watches  
*Coussin très rembourré pour montres Dames*

**SP19D/40** 65x 42 x 35 mm

**Stark wattierte Uhrspange HAU**  
Padded watch supports for gents' watches  
*Coussin très rembourré pour montres Hommes*

**SP19H/40** 83x 42 x 35 mm

**Stark wattierte Uhrspange HAU**  
Padded watch supports for gents' watches  
*Coussin très rembourré pour montres Hommes*

**SP19G/40** 83 x 42 x 43 mm

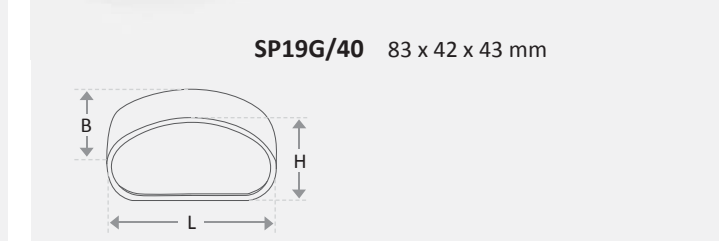

Maßangaben: Länge x Breite x Höhe | Dimensions: Length x Width x Height | Dimensions: Longueur x Largeur x Hauteur



**30-er gr. Hakenleiste (gelb / weiß), 2 gefederte Klappen**  
Strip of 30 hooks (gilt / silver), 2 elasticated flaps  
*Barre de 30 crochets (dorés / argent), 2 rabats à ressorts élastiques*

**4821D4** 447 x 277 x 25 mm



**14-er gr. Hakenleiste (gelb / weiß), 2 gefederte Klappen, Hochformat**  
Strip of 14 hooks (gilt / silver), 2 elasticated flaps, portrait  
*Barre de 14 crochets (dorés ou chromés), 2 rabats à ressorts élastiques, format vertical*

**4821D4X** 277 x 221 x 25 mm

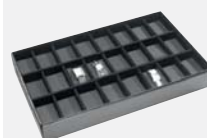

**24 ausgeschlagene Fächer 83 x 49 mm (+ Einlagen)**  
24 lined compartments 83 x 49 mm (+ inserts)  
*24 compartiments gainés 83 x 49 mm (+ coussinets)*

**4842/65** 227 x 447 x 65 mm



**Schaumstoff-Spangen**  
Foam watch supports  
*Coussin en mousse dense*

**SP37/48** 65 x 48 x 32 mm



**Gepolsterte Kissen**  
Padded cushions  
*Coussin gainé*

**KI90/55** 90 x 55 mm



**mit Tiefziehteil, 2 x 20 Fächer 125x 20 mm**  
with vacuum formed insert, 2 x 20 comp. 125 x 20 mm  
*avec insert thermoformé, 2 x 20 comp. 125 x 20 mm*

**4870T** 447 x 277 x 18 mm



**mit Tiefziehteil, 2 x 15 Fächer 125 x 28 mm**  
with vacuum formed insert, 2 x 15 comp. 125 x 28 mm  
*avec insert thermoformé, 2 x 15 comp. 125 x 28 mm*

**4871T** 447 x 277 x 18 mm



**mit Tiefziehteil, 9 Fächer 252 x 46 mm**  
with vacuum formed insert, 9 comp. 252 x 46 mm  
*avec insert thermoformé, 9 comp. 252 x 46 mm*

**4872T** 447 x 277 x 18 mm



**mit Tiefziehteil, 10 Fächer 252 x 41 mm**  
with vacuum formed insert, 10 comp. 41 x 252 mm  
*avec insert thermoformé, 10 comp. 41 x 252 mm*

**4873T** 447 x 277 x 18 mm



**12 überzogene Fächer, Gehäuse Ø max. 31 mm**  
12 lined compartments  
*12 compartiments gainés*

**4836** 447 x 277 x 18 mm

**mit Tiefziehteil, 12 Fächer**  
with vacuum formed insert, 12 comp.  
*avec insert thermoformé, 12 comp.*

**4836T** 447 x 277 x 18 mm



**Abschlußdeckel, flach**  
Top lid, flat  
*Couvercle, plat*

**48001** 447 x 277 x 5 mm

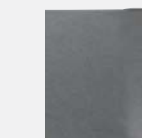

**48001X** 277 x 221 x 5 mm



**20 Fächer zzgl. Schaumstoff-Spangen**  
20 compartments for foam supports  
*20 cases pour coussins pour montres*

**4840/50** 447 x 277 x 50 mm



**6 Fächer zzgl. Schaumstoff-Spangen**  
6 compartments for foam supports  
*6 cases pour coussins pour montres*

**4840X6** 221 x 277 x 50 mm



**8 Fächer zzgl. Schaumstoff-Spangen**  
8 compartments for foam supports  
*8 cases pour coussins pour montres*

**4840X8** 221 x 277 x 50 mm



**8 Fächer zzgl. Schaumstoff-Spangen, mit LU-Auflage**  
8 compartments for foam supports  
*8 cases pour coussins pour montres*

**4840X8B** 277 x 221 x 50 mm



**18 ausgeschlagene Fächer 83 x 66 mm (+ Einlagen)**  
18 lined compartments 83 x 66 mm (+ inserts)  
*18 compartiments gainés 83 x 66 mm (+ coussins)*

**4843/65** 277 x 447 x 65 mm



**9 ausgeschlagene Fächer 83 x 66 mm (+ Einlagen)**  
9 lined compartments 83 x 66 mm (+ inserts)  
*9 compartiments 83 x 66 mm (+ coussins)*

**4843X60** 221 x 277 x 60 mm

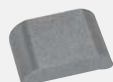

**Schaumstoff-Spangen**  
Foam watch supports  
*Coussin en mousse dense*

**SP37A/65** 75 x 65 x 32 mm



**Gepolsterte Kissen**  
Padded cushions  
*Coussin gainé*

**KI90/70** 90 x 70 mm



**10 Fächer zzgl. Schaumstoff-Spangen**  
10 compartments for foam supports  
*10 cases pour coussins pour montres*

**4840X10** 221 x 277 x 50 mm



**Schaumstoff-Spangen 30 mm breit**  
Foam supports 30 mm in width  
*Coussin pour montre en mousse 30 mm d'épaisseur*

**SP21** 32 x 80 x 35 mm



**Deckchen, 3 mm schaumstoffgepolstert**  
3 mm foam-padded cushion top cover  
*Napperon rembourré de 3 mm de mousse*

**48020** 430 x 260 mm



**48020X** 260 x 205 mm

Maßangaben: Länge x Breite x Höhe | Dimensions: Length x Width x Height | Dimensions: Longueur x Largeur x Hauteur

Koffer | Cases | Marmottes

VARIO LUX



DER KLASSIKER



**48K1/61** **Holzkofer, liegend, mit Ausfallklappe, Alu-Kantenprofil & Zahlenschlösser, unterschiedliche Oberflächen wählbar**  
 Flat wooden case, with forward opening flap, aluminum edge profile, combination locks, various outer finishes available  
*Marmotte verticale avec rabat amovible, profilés en aluminium et serrure de combinaison, différentes finitions extérieures possibles*

Dim. innen/int.: 450 x 285 x 180 mm  
 Dim. außen/ext.: 475 x 355 x 200 mm



**48K2/61** **Holzkofer, stehend, mit Ausfallklappe, Alu-Kantenprofil und Zahlenschlösser, unterschiedliche Oberflächen wählbar**  
 Upright wooden case, with forward opening flap, aluminum edge profile and combination locks, various outer finishes available  
*Marmotte verticale avec rabat amovible, profilés en aluminium et serrure de, différentes finitions extérieures possibles*

Dim. innen/int.: 560 x 225 x 375 mm  
 Dim. außen/ext.: 585 x 270 x 425 mm



**48K3/61** **Holzkofer, stehend, mit Ausfallklappe, Alu-Kantenprofil und Zahlenschlösser, unterschiedliche Oberflächen wählbar**  
 Upright wooden case, with forward opening flap, aluminum edge profile and combination locks, various outer finishes available  
*Marmotte verticale avec rabat amovible, profilés en aluminium et serrure de combinaison, différentes finitions extérieures possibles*

Dim. innen/int.: 455 x 280 x 375 mm  
 Dim. außen/ext.: 480 x 325 x 425 mm



**4827R** **Rollenkoffer mit Laptoptasche**  
 Wheeled case with laptop bag  
*Marmotte avec sacoche d'ordinateur portable*

Dim. innen/int.: 460 x 310 x 370 mm  
 Dim. außen/ext.: 515 x 350 x 425 mm

DER VIELSEITIGE

DER EXKLUSIVE



**48K14B** **Lederkofer, liegend, wattiert mit Ausfallklappe, Zahlenschlösser, Deckeltasche, in Schwarz**  
 Genuine leather case, padded, with forward opening flap, combination locks, pocket in lid, black  
*Marmotte en cuir avec rabat amovible, serrure de combinaison, poche intérieure, noir*

Dim. innen/int.: 455 x 255 x 220 mm  
 Dim. außen/ext.: 485 x 310 x 270 mm



**48K14A** **Lederkofer, liegend, wattiert mit Ausfallklappe, Zahlenschlösser, Deckeltasche, in Schwarz**  
 Genuine leather case, padded, with forward opening flap, combination locks, pocket in lid, black  
*Marmotte en cuir avec rabat amovible, serrure de combinaison, poche intérieure, noir*

Dim. innen/int.: 455 x 285 x 140 mm  
 Dim. außen/ext.: 485 x 340 x 165 mm



**Hülle mit Reißverschluss und gepolsterten Ecken**  
 Zipped case cover with padded corners  
*Housse avec fermeture éclair et coins rembourrés*

**48KU1P** für serie 48K1  
**48KU2P** für serie 48K2  
**48KU3P** für serie 48K3



**Stülphülle**  
 Pull-on case cover  
*Housse*

**48KU1** für serie 48K1  
**48KU2** für serie 48K2  
**48KU3** für serie 48K3



**Abnehmbarer Trolley mit Teleskopgriff für Montage an Koffer. Lieferbar in schwarz**  
**Rollendurchmesser: 125 mm**  
**Griffgesamtlänge: 980 mm**  
 Detachable trolley with telescopic handle to be fixed on cases. Available in black. Diameter of wheels: 125 mm, length of handle: 980 mm  
*Trolley amovible avec poignée télescopique pour marmottes. Livrable en noir. Diamètre des roues: 125 mm long. poignée: 980 mm*

FA-TA125

Modell: Koffer, liegend

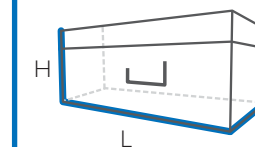

Modell: Koffer, liegend  
 Design: flat case  
 Modèle: format horizontal

**Maßangaben Länge x Breite x Höhe**  
 Dimensions: Length x Width x Height  
 Dimensions marmotte hauteur: Longueur x Largeur x Hauteur



ITEMS IN STOCK\*

ENTRY LEVEL SYSTEM

INSERTS IN  
GREY, WHITE & BLACK

PADS IN CALISTO WHITE

2 TRAY SIZES

## SERIE BASIC PLUS

Mit Basic Plus bieten wir Ihnen eine Kollektion, die jederzeit zur Verfügung steht. Die Lagerserie ist eine variable und preiswerte Variante. Stellen Sie Basisladen, Karteneinsätze und Aufmachungskarten nach Wunsch zusammen und kreieren Sie daraus auf Ihre Bedürfnisse abgestimmte Laden.

The Basic Plus collection is a flexible and well priced standard collection, which is readily available. Assemble by choosing outer trays, thermo-formed inserts and fitting pads as needed to create the perfect tray collection to suit your presentation needs.

*Basic Plus est une collection disponible à tout moment. Cette série standard représente une variante modulable et avantageuse. Vous choisissez les plateaux, les inserts thermoformés et les cartes et créez ainsi les plateaux correspondant à vos besoins.*

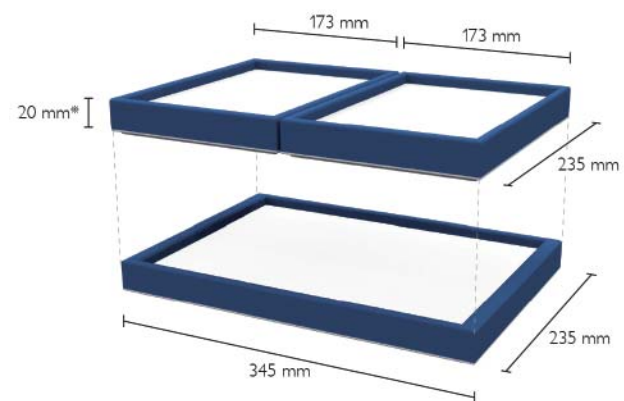

\*auch in der Höhe 25 mm, 30 mm, 35 mm, 45 mm, 50 mm und 75 mm erhältlich

Maßangaben: Länge x Breite x Höhe | Dimensions: Length x Width x Height | Dimensions: Longueur x Largeur x Hauteur



**Leerladen, passend für Einsätze**  
Empty trays, to take inserts  
*Plateaux vides pour insert thermoformé/plaque*

<b>3520</b>	345 x 235 x 20 mm
<b>3525</b>	345 x 235 x 25 mm
<b>3530</b>	345 x 235 x 30 mm
<b>3535</b>	345 x 235 x 35 mm
<b>3545</b>	345 x 235 x 45 mm
<b>3550</b>	345 x 235 x 50 mm
<b>3575</b>	345 x 235 x 75 mm



**Leerladen, passend für Einsätze**  
Empty trays, to take inserts  
*Plateaux vides pour insert thermoformé/plaque*

<b>3520X</b>	235 x 173 x 20 mm
<b>3525X</b>	235 x 173 x 25 mm
<b>3530X</b>	235 x 173 x 30 mm
<b>3535X</b>	235 x 173 x 35 mm
<b>3545X</b>	235 x 173 x 45 mm
<b>3550X</b>	235 x 173 x 50 mm
<b>3575X</b>	235 x 173 x 75 mm



**Wattierte Platte, glatt, für Lade 35..**  
Plain padded pad, for tray 35..  
*Plaque gainée, fin. main, lisse, pour plateaux 35..*

<b>3051</b>	330 x 220 mm
-------------	--------------



**Wattierte Platte, glatt, für Lade 35..X**  
Plain padded pad, for tray 35..X  
*Plaque gainée, fin. main, lisse, pour plateaux 35..X*

<b>3551</b>	220 x 157 mm
-------------	--------------

Tiefgezogene Einsätze | Thermoformed Inserts | *Inserts thermoformés*

BASIC PLUS

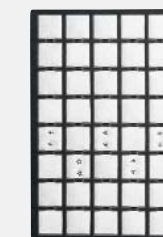

**40 vertiefte Fächer**  
40 deep-set compartments  
*40 compartiments surélevés*

<b>3016V</b>	330 x 220 mm
--------------	--------------



**Karte für Anhänger**  
Pad for pendant  
*Carte pour pend.*

<b>328</b>	35 x 35 mm
------------	------------



**Karte für Ohrhänge**  
Pad for drop earrings  
*Carte pour B.O.*

<b>328D</b>	35 x 35 mm
-------------	------------



**Karte für Stecker**  
Pad for stud earrings  
*Carte pour clous d'oreilles*

<b>328i</b>	35 x 35 mm
<b>328iH/6</b>	35 x 35 mm

\*except cases



Maßangaben: Länge x Breite x Höhe | Dimensions: Length x Width x Height | Dimensions: Longueur x Largeur x Hauteur



**20 vertiefte Fächer**  
20 deep compartments  
*20 compartiments surélevés*

**3016XV** 220 x 157 mm



**Winkelkarte für Ohrschmuck/Creolen**  
Angle pad, for studs/creoles  
*Coussinet pour B.O./Créoles*

**328Wi** 35 x 35 mm



**Karte für Anhänger (Haken 751)**  
Pad for pendant (Hook 751)  
*Carte pour pend. (Crochet 751)*

**328HA** 35 x 35 mm



**16 vertiefte Fächer**  
16 deep compartments  
*16 compartiments surélevés*

**3061XV** 220 x 157 mm



**Karte für Stecker**  
Pad for drop stud earrings  
*Carte pour clous d'oreilles*

**331IH/14** 50 x 30 mm



**Karte für Ohringe**  
Pad for drop earrings  
*Carte pour B.O.*

**331DH** 50 x 30 mm



**36 vertiefte Fächer**  
36 deep compartments  
*36 compartiments surélevés*

**3083V** 330 x 220 mm



**32 vertiefte Fächer**  
32 deep compartments  
*32 compartiments surélevés*

**3004V** 330 x 220 mm



**Karte für Anhänger/Brosche**  
Pad for pendant/brooch  
*Carte pour pend./broche*

**303** 45 x 35 mm



**Karte für Ohringe**  
Pad for drop earrings  
*Carte pour B.O.*

**303DH** 45 x 35 mm



**16 vertiefte Fächer**  
16 deep compartments  
*16 compartiments surélevés*

**3004XV** 220 x 157 mm



**Karte für Stecker**  
Pad for drop stud earrings  
*Carte pour clous d'oreilles*

**303iH** 45 x 35 mm  
**303iQ/M** 35 x 45 mm



**Karte für Anhänger (Haken 751)**  
Pad for pendant (Hook 751)  
*Carte pour pend. (Crochet 751)*

**303HA** 45 x 35 mm



**30 vertiefte Fächer**  
30 deep compartments  
*30 compartiments surélevés*

**3084V** 330 x 220 mm



**Karte für Anhänger/Brosche**  
Pad for pendant/brooch  
*Carte pour pend./broche*

**302** 55 x 38 mm



**Karte für Manschettenknöpfe**  
Pad for cufflinks  
*Carte pour boutons de manchettes*

**302A4** 38 x 55 mm



**10 vertiefte Fächer**  
10 deep compartments  
*10 compartiments surélevés*

**3003XV** 220 x 157 mm



**Karte für Creolen + Klammer 718**  
Pad for creole earrings + clip 718  
*Carte pour créoles + clip 718*

**302C2Q** 38 x 55 mm



**Karte für Ohringe**  
Pad for drop earrings  
*Carte avec fentes*

**302DH** 55 x 38 mm



**36 vertiefte Fächer**  
36 deep compartments  
*36 compartiments surélevés*

**3061V** 330 x 220 mm



**Karte für Anhänger**  
Pad for pendant  
*Carte pour pend.*

**331** 50 x 30 mm



**24 vertiefte Fächer**  
24 deep compartments  
*24 compartiments surélevés*

**3014V** 330 x 220 mm



**9 vertiefte Fächer**  
9 deep compartments  
*9 compartiments surélevés*

**3014XV** 220 x 157 mm



**Karte für Stecker**  
Pad for drop stud earrings  
*Carte pour clous d'oreilles*

**302iH/15** 55 x 38 mm  
**302iQ** 38 x 55 mm



**Karte für Anhänger (Haken 751)**  
Pad for pendant (Hook 751)  
*Carte pour pend. (Crochet 751)*

**302HA** 55 x 38 mm



**Karte für Ketten mit Anhänger**  
Pad for chain with pendant  
*Carte pour chaîne avec pend*

**302T** 55 x 38 mm



**Winkelkarte für Stecker/Creolen**  
Angle Pad for drop stud earrings/hoops  
*Carte recourbée pour dormeuses/B.O./Créoles*

**302Wi/H** 55 x 38 mm  
**302Wi/Q** 38 x 55 mm



**Karte für Anhänger/Brosche**  
Pad for pendant/brooch  
*Carte pour pend./broche*

**301** 45 x 70 mm



**Karte für Stecker**  
Pad for drop stud earrings  
*Carte pour clous d'oreilles*

**301iH** 70 x 45 mm



**Karte für Ohrringe**  
Pad for drop earrings  
*Carte pour B.O.*

**301DH** 70 x 45 mm



**Karte für Manschettenknöpfe**  
Pad for cufflinks  
*Carte pour boutons de manchettes*

**301A4** 45 x 70 mm



**16 vertiefte Fächer**  
16 deep compartments  
*16 compartiments surélevés*

**3002V** 330 x 220 mm



**8 vertiefte Fächer**  
8 deep compartments  
*8 compartiments surélevés*

**3002XV** 220 x 157 mm



**18 vertiefte Fächer**  
18 deep compartments  
*18 compartiments surélevés*

**3149V** 330 x 220 mm



**9 vertiefte Fächer**  
9 deep compartments  
*9 compartiments surélevés*

**3149XV** 220 x 157 mm



**Karte für Clips**  
Pad for clips  
*Carte pour clips*

**301B3H** 70 x 45 mm  
**301B3Q** 45 x 70 mm



**Karte für Creolen + Klammer 718**  
pad for creole earrings + clip 718  
*carte pour créoles + clip 718*

**301C2Q** 45 x 70 mm



**Karte für Ketten mit Anhänger**  
Pad for chain with pendant  
*Carte pour chaîne avec pend.*

**301TH** 70 x 45 mm  
**301TQ** 45 x 70 mm



**Winkelkarte für Stecker/Creolen**  
Angle Pad for drop stud earrings/hoops  
*Carte recourbée pour dormeuses/B.O./Créoles*

**301Wi/H** 70 x 45 mm  
**301Wi/Q** 45 x 70 mm



**28 Fächer**  
28 compartments  
*28 compartiments surélevés*

**3066** 220 x 330 mm



**22 vertiefte Fächer**  
22 deep compartments  
*22 compartiments surélevés*

**3164** 220 x 330 mm



**Karte für Nadeln**  
Pad for pins  
*Carte pour épingles de bijouterie*

**311** 78 x 25 mm



**Karte für Krawatten-Halter**  
Pad for tie-pins  
*Carte pour pincés-cravate*

**311F** 78 x 25 mm

Maßangaben: Länge x Breite x Höhe | Dimensions: Length x Width x Height | Dimensions: Longueur x Largeur x Hauteur



**12 vertiefte Fächer**  
12 deep compartments  
*12 compartiments surélevés*

**3001V** 330 x 220 mm



**6 vertiefte Fächer**  
6 deep compartments  
*6 compartiments surélevés*

**3001XV** 220 x 157 mm



**Karte für Creolen + Klammer 718/719**  
Pad for creole earrings + clip 718/719  
*Carte pour créoles + clip 718/719*

**308C2Q** 78 x 55 mm



**Karte für Clips**  
Pad for clips  
*Carte pour clips*



**308B3Q** 78 x 55 mm

**308B3H** 78 x 55 mm



**Karte für Anhänger/Collier**  
Pad for pendant/necklace  
*Carte pour pend./collier*



**308TH** 78 x 55 mm



**308TQ** 55 x 78 mm



**Karte für Brosche**  
Pad for brooch  
*Carte pour broche*

**308** 78 x 55 mm



**8 vertiefte Fächer**  
8 deep compartments  
*8 compartiments surélevés*

**3011V** 330 x 220 mm



**Karte für Anhänger/Brosche**  
Pad for pendant/brooch  
*Carte pour pend./broche*

**380** 105 x 75 mm



**4 vertiefte Fächer**  
4 deep compartments  
*4 compartiments surélevés*

**3011XV** 220 x 157 mm



**Karte für Collier**  
Pad for necklace  
*Carte pour collier*



**380TH** 105 x 75 mm

**380TQ** 105 x 75 mm

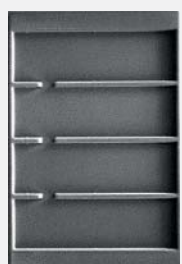

**4 Fächer**  
4 compartments  
*4 compartiments*

**3012** 330 x 220 mm



**Karte Glatt**  
Pad smooth  
*Carte lisse*

**320** 210 x 65 mm



**2 Fächer**  
2 compartments  
*2 compartiments*

**3013** 330 x 220 mm



**Karte glatt**  
Plain Pad  
*Carte lisse*

**381** 208 x 153 mm



**Karte mit rundem Tambour**  
Pad with raised, round neck form  
*Carte avec tambour*

**381TA** 208 x 153 mm



**Karte mit rundem Tambour und Gummi-Spanner**  
Pad with a round raised neck form and 2 elastics  
*carte avec tambour surélevé, rond et avec 2 élastiques de maintien*

**381TA/5** 208 x 153 mm



**11 Fächer**  
11 compartments  
*11 compartiments*

**3007** 330 x 220 mm



**Karte für Armbänder**  
Pad for bracelets  
*Carte pour bracelets*

**322A2** 25 x 210 mm



**5 Fächer**  
5 compartments  
*5 compartiments*

**3007X** 220 x 157 mm



**8 Fächer**  
8 compartments  
*8 compartiments*

**3008** 330 x 220 mm

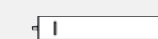

**Karte für Armbänder**  
Pad for bracelets  
*Carte pour bracelets*

**321A2** 35 x 210 mm



**6 Fächer, Stege hoch**  
6 compartments, high partitions  
*6 compartiments, séparations hautes*

**3009** 330 x 220 mm



**8 Fächer für Brillen, Stege hoch**  
8 compartments for glasses, high partitions  
*8 compartiments pour lunettes, séparations hautes*

**3018** 330 x 220 mm

Maßangaben: Länge x Breite x Höhe | Dimensions: Length x Width x Height | Dimensions: Longueur x Largeur x Hauteur



**6 Fächer für Brillen, Stege hoch**  
6 compartments for glasses, high dividers  
*6 compartiments pour lunettes, séparations hautes*

**3019** 330 x 220 mm



**24 Fächer, Stege hoch**  
24 compartments, high dividers  
*24 compartiments, séparations hautes*

**3064** 330 x 220 mm



**35 Fächer, Stege hoch**  
35 compartments, high dividers  
*35 compartiments, séparations hautes*

**3065** 330 x 220 mm



**72 Fächer, Stege hoch**  
72 compartments, high dividers  
*72 compartiments, séparations hautes*

**3062** 330 x 220 mm



**Schaumstoffeinlage für 95 Ringe, quer, Schlitz versetzt**  
Foam insert for 95 rings, landscape, slots staggered  
*Intérieur mousse p. 95 bagues, fentes horizontales en quinconce*

**3023/95** 330 x 220 mm



**Schaumstoffeinlage für 46 Ringe, quer, Schlitz versetzt**  
Foam insert for 46 rings, slots staggered, landscape  
*Intérieur mousse p. 46 bagues, fentes horizontales en quinconce*

**3024/46** 220 x 157 mm



**Schaumstoffeinlage für 104 Ringe, hoch, Schlitz versetzt**  
Foam insert for 104 rings, portrait, slots staggered  
*Intérieur mousse p. 104 bagues, fentes vertical en quinconce*

**3023/104** 330 x 220 mm



**Schaumstoffeinlage glatt zur freien Dekoration**  
Foam insert, plain, no cuts  
*Intérieur mousse lisse, sans fentes*

**3024E1** 220 x 157 mm



**Schaumstoffeinlage glatt zur freien Dekoration**  
Foam insert, plain, no cuts  
*Intérieur mousse lisse, sans fentes*

**3023E1** 330 x 220 mm

**Tiefgezogener Einsatz für Ketten, 18-er Hakenleiste (gold-/silberfarben), Tasche unten**  
Chain insert, strip of 18 hooks (gilt/chrome), pocket  
*Insert thermoformé avec barre de 18 crochets, (dorés/argentés), poche en bas*

**3079** 330 x 220 mm



**Kettenlade, 19-er Hakenleiste (gold-/silberf.), Hochformat**  
Chain tray, strip of 19 hooks, portrait (gilt/chrome)  
*Plateau, barre de 19 crochets (dorés/argentés), format vertical*

**3521** 345 x 235 x 20 mm



**Kettenlade, 29-er Hakenleiste (gold-/silberf.), Querformat**  
Chain tray, strip of 29 hooks, landscape (gilt/chrome)  
*Plateau, barre de 29 crochets (dorés/argentés), format horizontal*

**3522** 345 x 235 x 20 mm



**Tiefgezogener Einsatz für 40 Ringe, kaschierte Bäckchen, Querformat**  
Vacuum-formed insert for 40 rings, landscape (laminated foam ring inserts glued in)  
*Insert thermoformé p. 40 bagues (mousses contrecollées), format horizontal*

**3082Q** 330 x 220 mm



**Tiefgezogener Einsatz für 20 Ringe, kaschierte Bäckchen, Querformat**  
Vacuum-formed insert for 20 rings, landscape (laminated foam ring inserts glued in)  
*Insert thermoformé p. 20 bagues (mousses contrecollées), format horizontal*

**3082EXQ** 220 x 157 mm



**Tiefgezogener Einsatz: 14 Uhren (inkl. POLY-Spangen)**  
Insert: 14 watches (incl. POLY- supports)  
*Insert: 14 montres (supports POLY inclus)*

**3039D14** 330 x 220 mm



**Eingerichtete Lade: 4 Fächer mit tiefgezogenen Seitenrastern für Zwischenlagen 3532Z1, für Armreife.**  
Bangle tray. 4 comp. with vacuum formed grids on either side to take loose dividers 3532Z1.  
*4 compartiments à encoches thermoformées pour séparations amovibles 3532Z1 pour joncs.*

**3532D1** 345 x 235 x 75 mm



**Tiefgezogener Einsatz: 12 Uhren (inkl. POLY-Spangen)**  
Insert: 12 watches (incl. POLY- supports)  
*Insert: 12 montres (supports POLY inclus)*

**3087D12** 330 x 220 mm



**Zwischenlagen passend für 3532D1**  
Loose dividers suitable for tray 3532D1  
*séparations amovibles pour plateau 3532D1*

**3532Z1**

Maßangaben: Länge x Breite x Höhe | Dimensions: Length x Width x Height | Dimensions: Longueur x Largeur x Hauteur

Koffer & Zubehör | Cases & Accessories | Marmottes & Accessoires

BASIC PLUS



**ALU-Schild für Lade (gold-/silberfarben)**  
Alu label plate for trays (gilt/chrome)  
*Plaque en ALU (dorée/argentée) pour plateaux*

**704A**  
**Maße ALU-Schild/dim.** alu label plate/dim. plaque en alu:  
10 x 26 mm  
**Maße Etikett/dim.** alu label/dim. étiquette:  
8 x 16 mm

**Etikettenrahmen für Laden (gold-/silberfarben)**  
Label frame for trays (gilt/chrome)  
*Cadre étiquette (doré/argenté) pour plateaux*

**704E**  
**Maße Etikettenrahmen/dim.** label frame/dim. cadre étiquette:  
10,1 x 38 mm  
**Maße Etikett/dim.** alu label/dim. étiquette:  
9,9 x 26 mm

## DER SOLIDE



**Holzkofer, stehend, mit Ausfallklappe, Alu-Kantenprofil und Zahlenschlösser, unterschiedliche Oberflächen wählbar**  
Upright wooden case, with forward opening flap, aluminum edge profile and combination locks, various outer finishes available  
*Marmotte verticale avec rabat amovible, profilés en aluminium et serrure de, différentes finitions extérieures possibles*

**3100/61**  
Dim. innen/int.:  
350 x 240 x 375 mm  
Dim. außen/ext.:  
375 x 280 x 425 mm

**Klettband-Gurte, schwarz**  
Velcro strap in black  
*courroie velcro noire*

**7025/100** 1000 mm  
**7025/130** 1300 mm  
**7025/150** 1500 mm  
**7025/180** 1800 mm

**Abschlußdeckel, flach**  
Flat top lid  
*Couvercle, plat*

**35001** 345 x 235 x 5 mm

**Abschlußdeckel, flach**  
Flat top lid  
*Couvercle, plat*

**35001X** 235 x 173 x 5 mm

**Modell: Koffer, stehend**

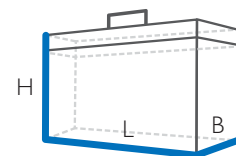

**Modell: Koffer, stehend | Design: upright case | Modèle: format vertical**

**Maßangaben Länge x Breite x Höhe**  
Dimensions: Length x Width x Height  
*Dimensions marmotte hauteur: Longueur x Largeur x Hauteur*



INDIVIDUAL INSERTS

SPECIAL DESIGNS ON REQUEST

## VORLAGEETUIS | PRESENTATION BOXES | ÉCRINS DE PRÉSENTATION



**Vorlageetui mit Magnetverschluss, zzgl. Ringeinlage**  
Presentation case with magnet closure, plus ring insert  
*Coffret de présentation avec fermeture aimantée, mousse avec fentes pour bagues à commande séparément*

**31119V2T / E26** 198x388x48mm



**Vorlageetui, lackiert, mit 2x3 Fächer für Uhrspangen SP19**  
Lacquered presentation case with 2x3 compartments to take watch supports SP19  
*Coffret de présentation, laqué, avec 2x3 compartiments pour supports de montre SP19*

**12002V1** 250 x 300 x 80 mm



**Vorlageetui mit Magnetverschluss, Ringeinlage im Boden- und Deckelteil**  
Presentation case with magnet closure, ring insert in top and bottom part  
*Coffret de présentation avec fermeture aimantée, mousse avec fentes pour bagues dans le couvercle et dans le plateau*

**36028V2D/G** 345 x 172 x 33 mm



**Lackierte Box mit Schublade**  
Lacquered box with drawer  
*Coffret laqué avec tiroir*

**16103V1** 225 x 305 x 100 mm



**Vorlageetui mit 24 Ringe in Einzelbäckchen 35 x 35 mm**  
Presentation case with 24 rings, large square ring containers  
*Coffret de présentation avec 24 bagues, cases carrées*

**1928R24** 190 x 290 x 40 mm

**24 x 2 Ringe in Einzelbäckchen**  
24 x 2 rings, large square ring containers  
*24 x 2 bagues, cases carrées*

**1928R24F**



**Vorlageetui mit Ringwulsten (10 Ringreihen)**  
Presentation case with cont. covered sponge rolls (10 ring rows)  
*Coffret de présentation avec rouleaux, 10 rangées de bagues*

**1930W** 235 x 345 x 45 mm

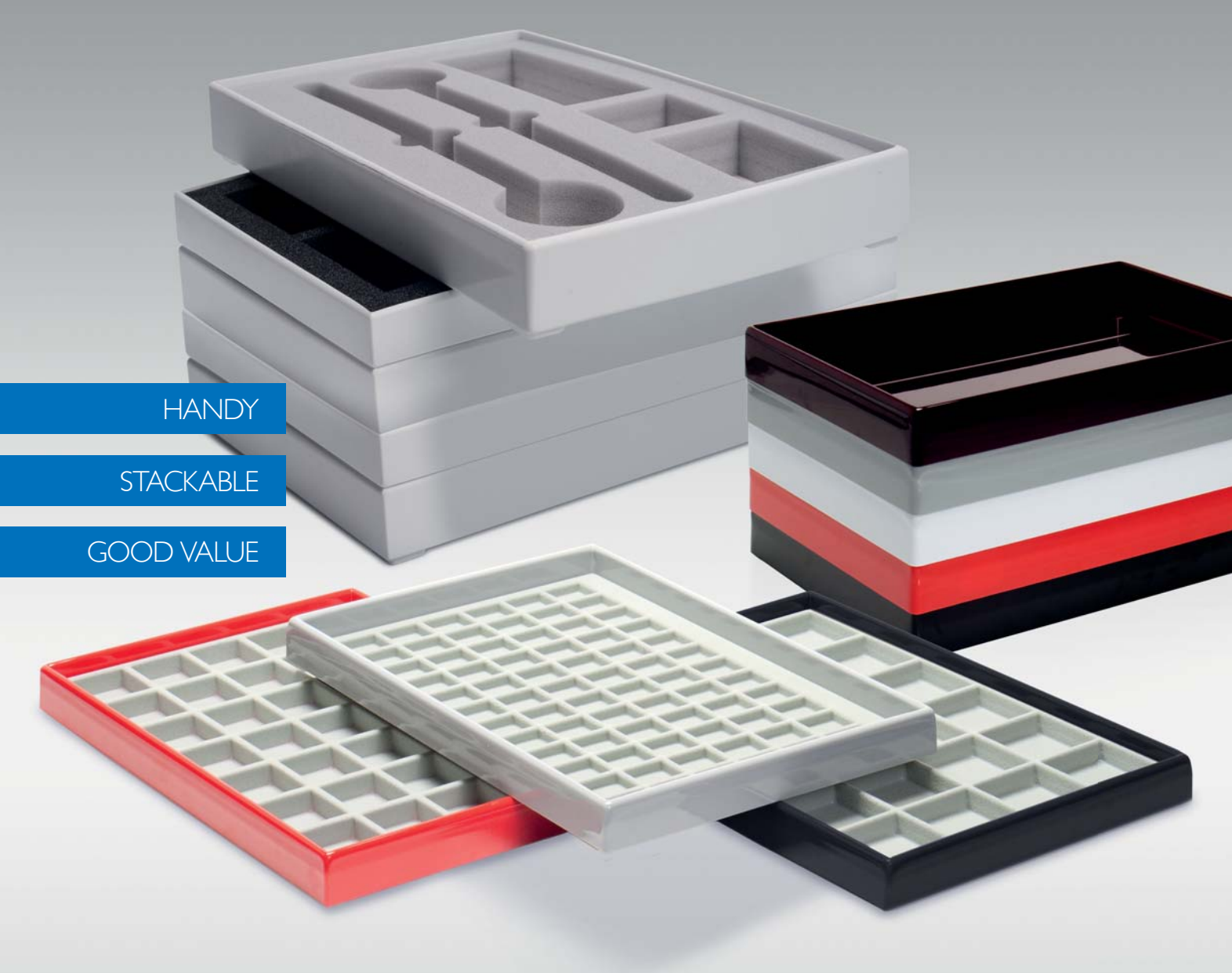

HANDY

STACKABLE

GOOD VALUE

Maßangaben: Länge x Breite x Höhe | Dimensions: Length x Width x Height | Dimensions: Longueur x Largeur x Hauteur

**SAFE STORAGE**

**SPECIAL COLOURS ON REQUEST**

**Tiefgezogene, stapelbare Laden aus Polystyrol. Lieferbare Farben: weiß, schwarz, grau, rot, gelb**  
 Vacuum formed, stackable trays of polystyrene. Available colours: white, black, grey, red, yellow  
*Plateaux empilables thermoformés en poly. Couleurs livrables: blanc, noir, gris, blanc, rouge, jaune*

<b>3901</b>	Dim. innen/int.: 330 x 220 x 25 mm Dim. außen/ext.: 350 x 240 x 28 mm
<b>3902</b>	Dim. innen/int.: 330 x 220 x 35 mm Dim. außen/ext.: 350 x 240 x 40 mm
<b>3902/45</b>	Dim. innen/int.: 330 x 220 x 45 mm Dim. außen/ext.: 350 x 240 x 50 mm

## TABLETS FÜR PRODUKTION UND LAGER

Sicher transportieren und lagern können Sie Ihre wertvollen Produkte mit den bewährten Poly-Tablets von Kling. Die stabilen und pflegeleichten Außenladen in Kombination mit den passenden Einsätzen mit beflockter Oberfläche sind bestens geeignet für den täglichen Einsatz in Industrie und Handel. Die Außenladen sind in verschiedenen Höhen und vielen Farben verfügbar, die Einsätze sind mit unterschiedlichen Einteilungen und ebenfalls in einer Vielzahl an Farben erhältlich.

Poly trays for production and storage. Safely carry and store your valuable products with the tried and trusted poly trays, proudly made by Kling. These solid and low maintenance trays, combined with matching flocked inserts, are ideal for every-day use in industry and trade. Trays are available in several heights and colours, with the inserts available with a variety of practical compartments and a selection of colours.

*Plateaux en poly pour la production et le stockage. Les plateaux KLING en poly vous offrent un transport sécurisé et un stockage de vos précieux produits. Les plateaux à la fois solides et faciles d'entretien combinés à des inserts en finition floquée sont parfaits pour une utilisation journalière dans l'industrie et le commerce. Les plateaux existent dans différentes tailles et couleurs, les inserts avec un nombre de compartiments différents et également dans différentes couleurs.*

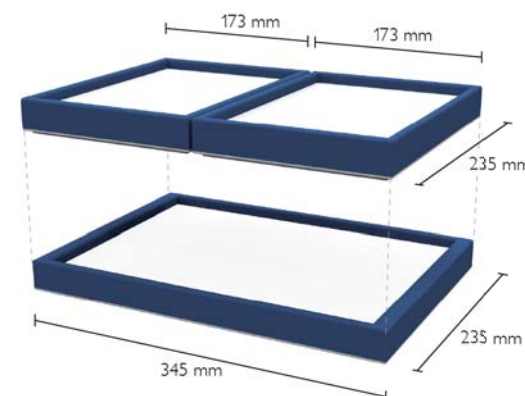

**NEW**

**SPECIAL COLOURS ON REQUEST**

**Tiefgezogene, stapelbare Industrie-Lade aus Polystyrol, leer**  
 Vacuum formed, stackable trays of polystyrene  
*Plateaux empilables thermoformés en poly*

<b>3911/25</b>	Dim. innen/int.: 330 x 220 x 25 mm Dim. außen/ext.: 350 x 240 x 32 mm
<b>3911/35</b>	Dim. innen/int.: 330 x 220 x 35 mm Dim. außen/ext.: 350 x 240 x 42 mm
<b>3911/45</b>	Dim. innen/int.: 330 x 220 x 45 mm Dim. außen/ext.: 350 x 240 x 52 mm



**Gespritzte, stapelbare Laden. Lieferbare Farbe: naturbeige**  
Injection moulded, stackable trays.  
Available colour: natural beige  
*Plateaux empilables injectés. Couleur livrable: beige nature*

**3903**

Dim. innen/int.: 330 x 220 x 22 mm  
Dim. außen/ext.: 345 x 235 x 25 mm

**3904**

Dim. innen/int.: 330 x 220 x 32 mm  
Dim. außen/ext.: 345 x 235 x 35 mm



**3903X**

Dim. innen/int.: 222 x 159 x 22 mm  
Dim. außen/ext.: 235 x 172 x 25 mm

**3904X**

Dim. innen/int.: 222 x 159 x 32 mm  
Dim. außen/ext.: 235 x 172 x 35 mm



**Schaumstoffeinlage in grau. Passend für 3901, 3902, 3903, 3904, 3911**  
Foam insert in grey to fit trays 3901, 3902, 3903, 3904, 3911  
*Insert de mousse en gris . convient à 3901, 3902, 3903, 3904, 3911*

**3901E** 330 x 220 x 4 mm



**Ring-Einlage für 95 Ringe, quer, Schlitz versetzt**  
Ring insert for 95 rings, landscape, slots staggered  
*Insert en mousse pour 95 bagues, fentes horizontales en quinconce*

**3023/95** 330 x 220 mm

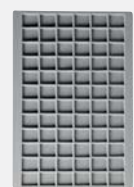

**Einsatz mit 72 Fächer, Stege hoch**  
Insert with 72 compartments, high dividers  
*Insert thermoformé avec 72 compartiments, séparations hautes*

**3062** 330 x 220 mm



**Einsatz mit 24 Fächer, Stege hoch**  
Insert with 24 compartments, high dividers  
*Insert thermoformé avec 24 compartiments, séparations hautes*

**3064** 330 x 220 mm



**Einsatz mit 35 Fächer, Stege hoch**  
Insert with 35 compartments, high dividers  
*Insert thermoformé avec 35 compartiments, séparations hautes*

**3065** 330 x 220 mm



**Einsatz mit 6 Fächer, Stege hoch**  
Insert with 6 compartments, high dividers  
*Insert thermoformé avec 6 compartiments, séparations hautes*

**3009** 330 x 220 mm



**8 Fächer**  
8 compartments  
*8 compartiments*

**3008** 330 x 220 mm



**11 Fächer**  
11 compartments  
*11 compartiments*

**3007** 330 x 220 mm



**5 Fächer**  
5 compartments  
*5 compartiments*

**3007X** 220 x 157 mm

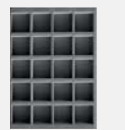

**5x4 Fächer**  
5x4 compartments  
*5x4 compartiments*

**3082EX** 220 x 157 mm



**Ringeinlage für 46 Ringe, quer, Schlitz versetzt**  
Ring insert for 46 rings, slots staggered, landscape  
*Mousse avec 46 fentes horizontales en quinconce pour bagues*

**3024/46** 220 x 157 mm

**WEITERE FACH-EINSÄTZE AB S. 95**

FURTHER INSERTS STARTING ON PAGE 95  
AUTRES INSERTS THERMOFORMÉS À PARTIR DE LA PAGE 95

**Individuell gefertigte Einsätze | Customized Inserts | Inserts fabriqués sur mesure**

**INDIVIDUELL GEFERTIGTE EINSÄTZE**

CUSTOMISED INSERTS  
INSERTS FABRIQUÉS SUR MESURE



Sie haben spezielle Anforderungen an die Einsätze, die passgenau auf Ihre Produkte abgestimmt sein sollen? Dann sollten Sie unbedingt mit uns sprechen! Gerne entwickeln wir individuelle Einsätze für Ihre Bedürfnisse und fertigen diese aus geschnittenen Schäumen ab 50 Stück oder Vakuum geformtem Veloursmaterial ab einer Menge von 250 Stück.

Do you have need for fully customised inserts to support your products? We are happy to develop individual applications for your

specific needs. These customised pieces may be machine cut at a minimum quantity of 50 pieces, or vacuum-formed in a flock material at a minimum quantity of 250 pieces. Please contact us for further assistance.

*Vous souhaitez des inserts à la forme de vos produits? Alors, contactez-nous! Il est tout à fait envisageable de fabriquer des inserts sur mesure, répondant à vos besoins, soit en mousse à partir d'une quantité minimum de 50pcs ou soit en velours traité sous vide à partir d'une quantité minimum de 250pcs.*



Druckbeispiel / print example / exemple d'impression

**DRUCK AUF ANFRAGE**

PRINT ON REQUEST  
IMPRESSION SUR DEMANDE

# ZUBEHÖR

ACCESSORIES | ACCESSOIRES

Vorlagetabletts | Presentation trays | *Plateaux de présentation* 111

Aufmachungskarten | Pads | *Cartes* 112-118

Nadeln | Pins | *Épingles* 119

X-Press-Boxen | X-Press-Boxes | *Boîtes coquilles* 120-121



PERFECT PRESENTATION

Maßangaben: Länge x Breite x Höhe | Dimensions: Length x Width x Height | *Dimensions: Longueur x Largeur x Hauteur*

## VORLAGETABLETTS

Oft sind es die kleinen Dinge, die große Wirkung zeigen - das Vorlagetablett gehört zu einem durchgängigen und einheitlichen Auftritt exklusiver Marken dazu. Denn wie ein Schmuckstück wirkt, entscheidet auch die richtige Präsentation.

It is often the small things that make a great impact. Presentation trays form an important part of an integrated presentation of exclusive brands. Allow Kling's presentation trays to enhance the first impression of each and every jewellery piece.

*Ce sont souvent les détails qui font la différence. Les plateaux de présentation de comptoir jouent constamment un rôle prépondérant dans la présentation exclusive de chaque bijou.*



**Holzrahmen (natur), glatte Einlage (wattiert)**  
Wooden frame with plain padded insert  
*Cadre en bois brut, fonds gainé (rembourré)*

**1659** 352 x 242 x 20 mm



**Überzogener Holzrahmen, glatte Einlage (wattiert)**  
Covered wooden frame with plain padded insert  
*Cadre en bois gainé, fonds gainé (rembourré)*

**1655** 345 x 235 x 16 mm



**Vorlagetablett mit 2 Ringwulsten über die Breitseite**  
Presentation tray with 2 rolls (one ring row) along wide side  
*plateau de présentation de comptoir avec rigole pour bagues, sur la longueur*

**1655/1** 345 x 235 x 20 mm



**POLY-Schale, mit Einlage**  
Poly tray, lined  
*Bac en POLY, fonds gainé*

**1652P** 320 x 230 x 15 mm





DELIVERY FROM STOCK

100% COTTON

MADE IN GERMANY

## AUFMACHUNGSKARTEN

Die Aufmachungskarten sind in folgenden Materialien erhältlich: PIC, DOMY, Quinel und Calisto. Es wird zwischen den maschinell hergestellten Heißsiegelkarten (Artikelnummern mit Vornummer 6) und den von Hand eingeschlagenen Aufmachungskarten (Artikelnummern mit Vornummer 3) unterschieden.

The pads are available in the following materials: PIC, DOMY, Quinel and Calisto. There is the distinction between heat-welded pads which are machine-made (article numbers beginning with 6) and hand-finished pads (article numbers beginning with 3).

Les cartes sont disponibles en différents matériaux: PIC, DOMY, Quinel et Calisto. Les cartes sont disponibles en deux finitions différentes à savoir en finition machine (référence d'article commençant par un 6) et en finition main (référence d'article commençant par un 3).

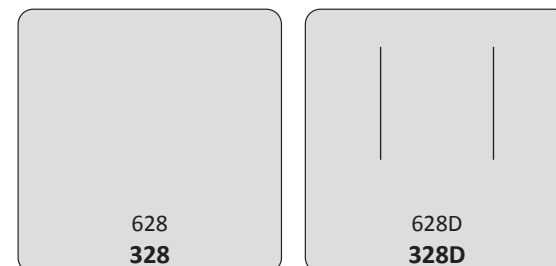

35 x 35 mm

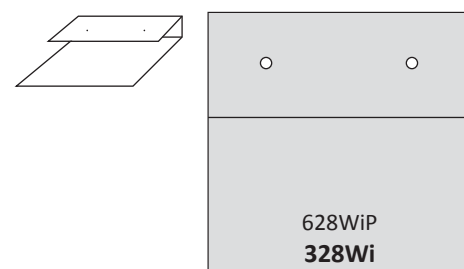

35 x 35 mm

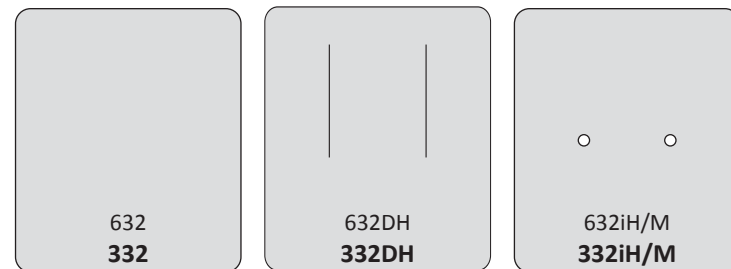

35 x 30 mm



45 x 35 mm

45 x 35 mm

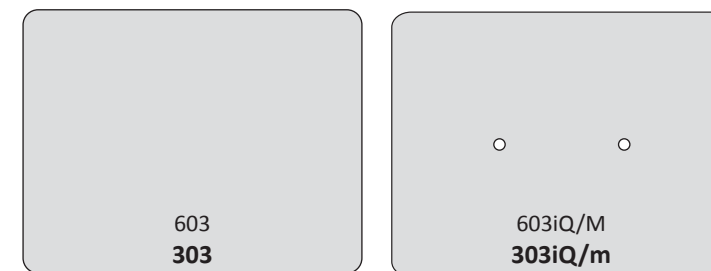
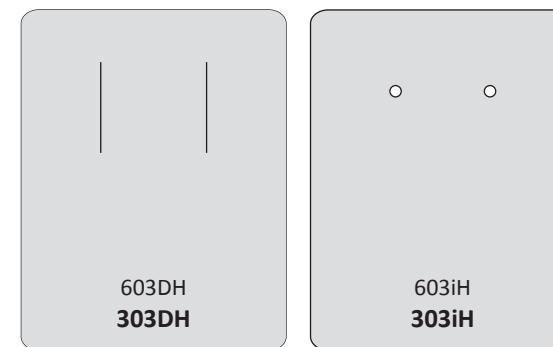
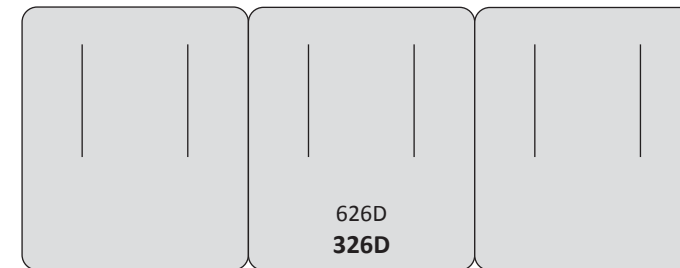

35 x 45 mm

35 x 45 mm

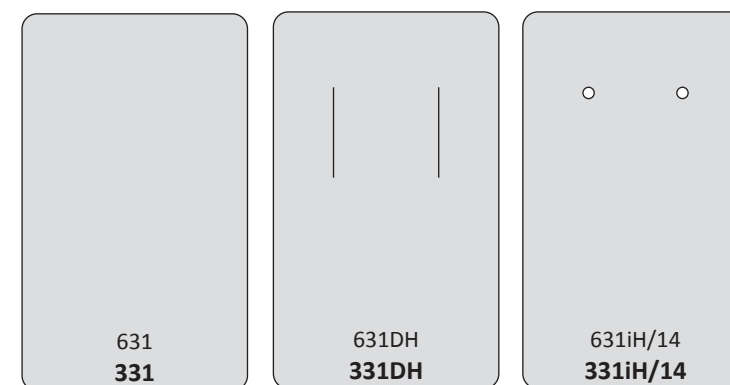

50 x 30 mm

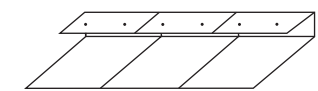
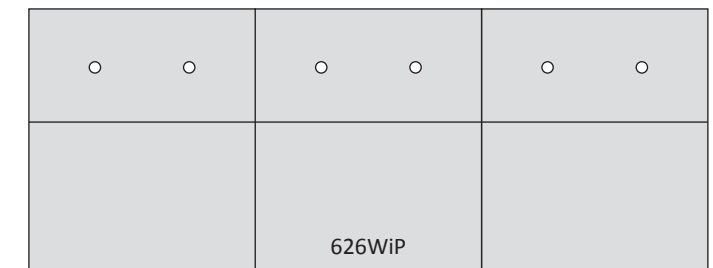
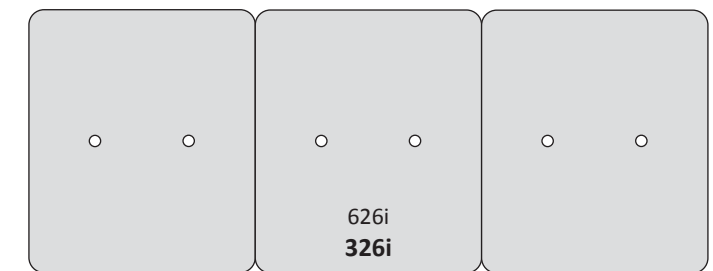

35 x 90 mm



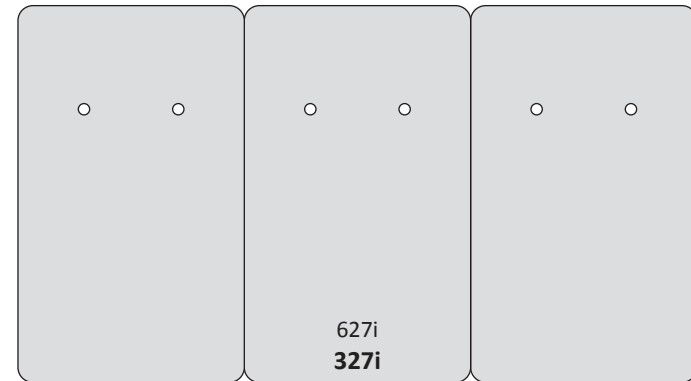
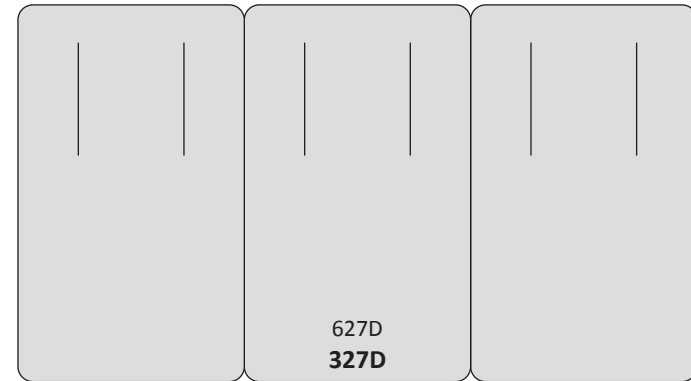
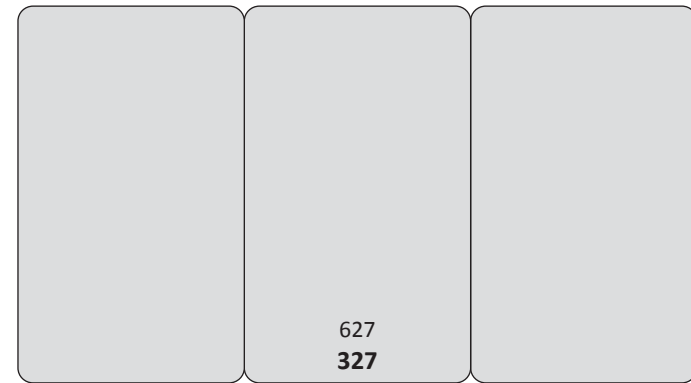
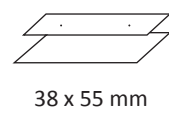
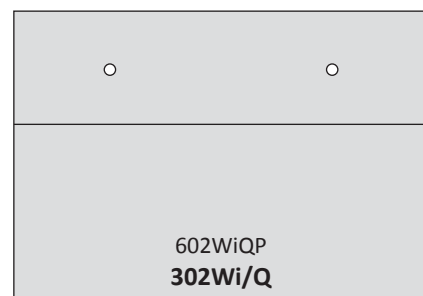
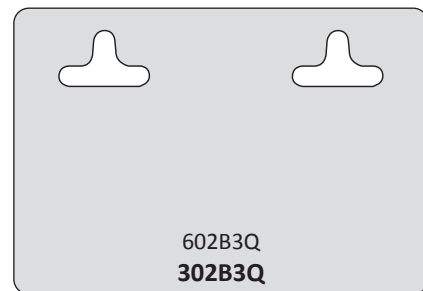
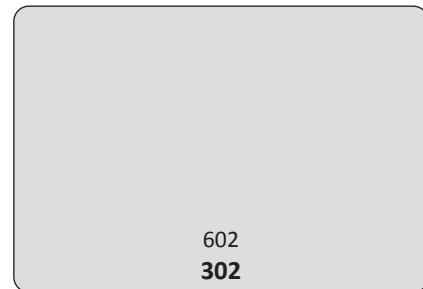
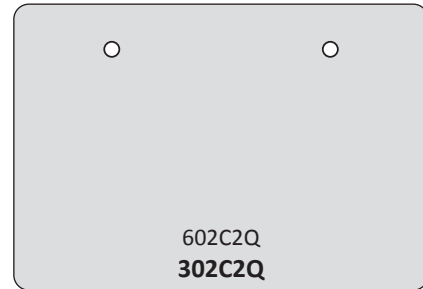
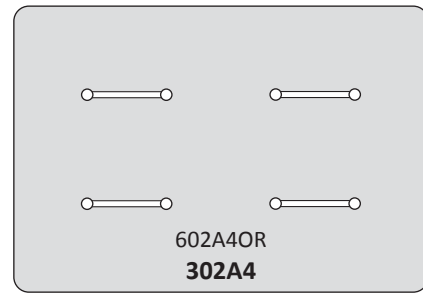

50 x 90 mm

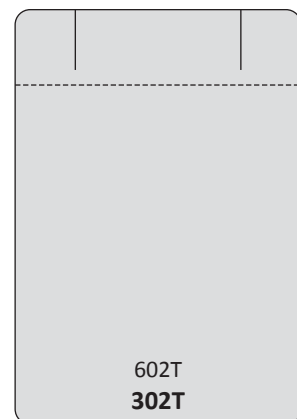
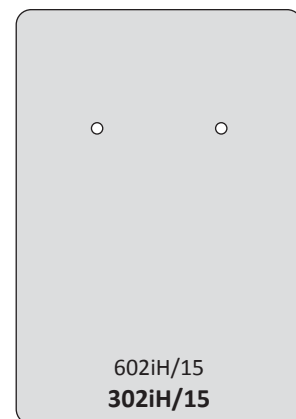
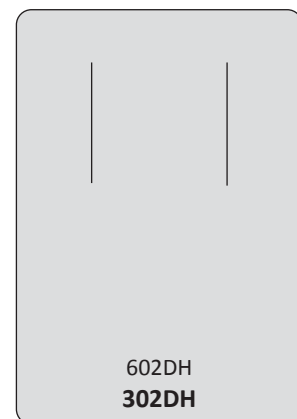

55 x 38 mm

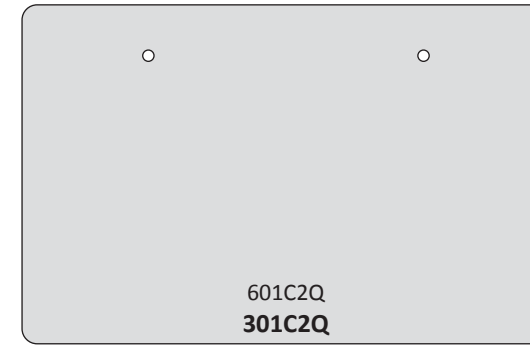
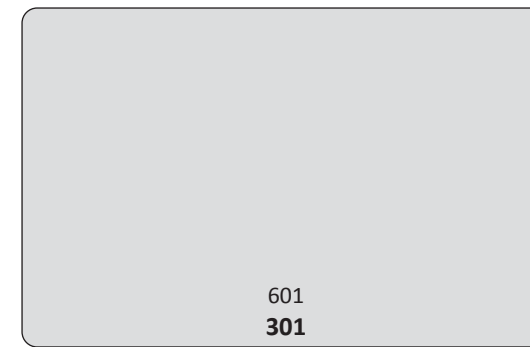

45 x 70 mm

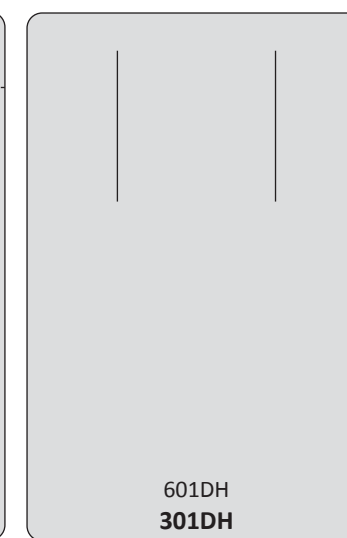
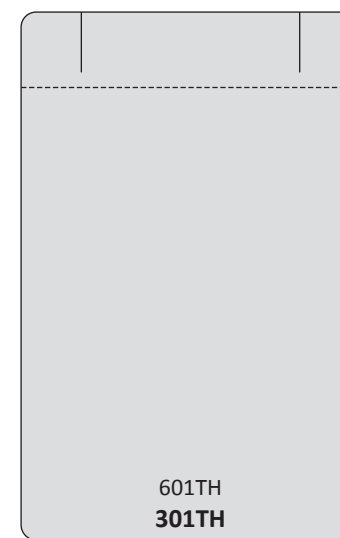
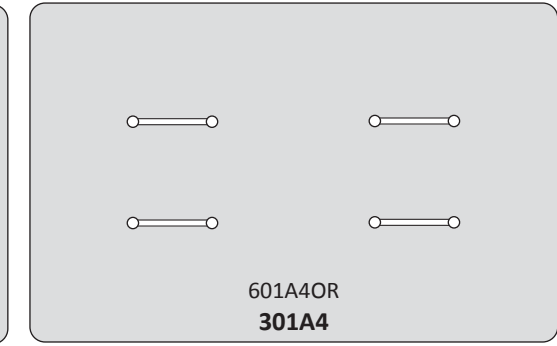
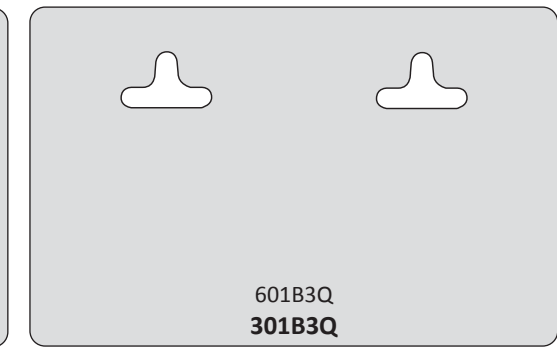

70 x 45 mm

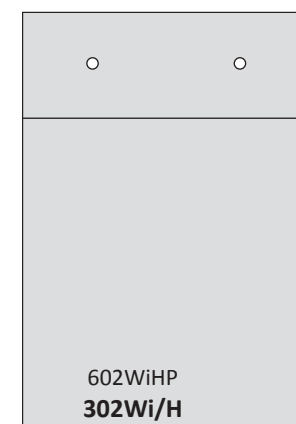

55 x 38 mm

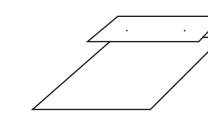
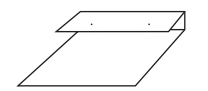

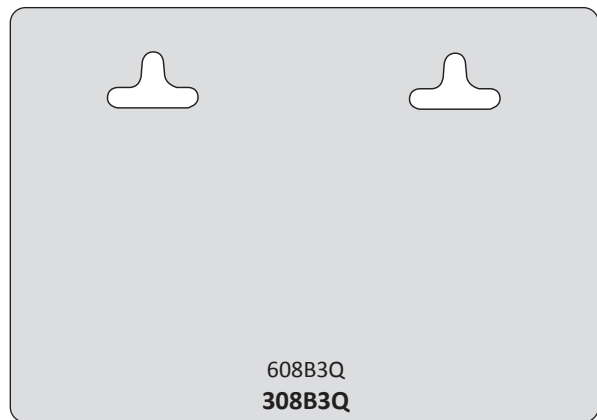
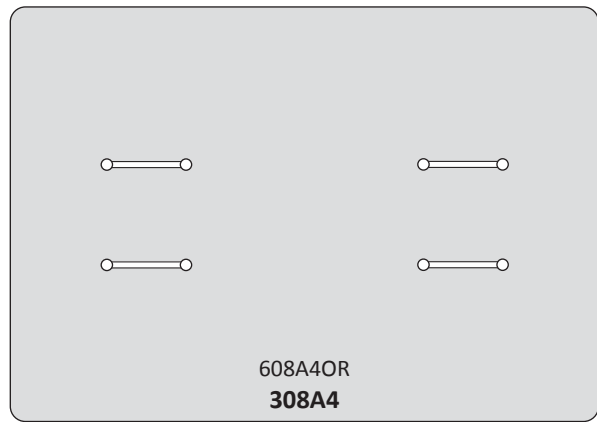

55 x 78 mm

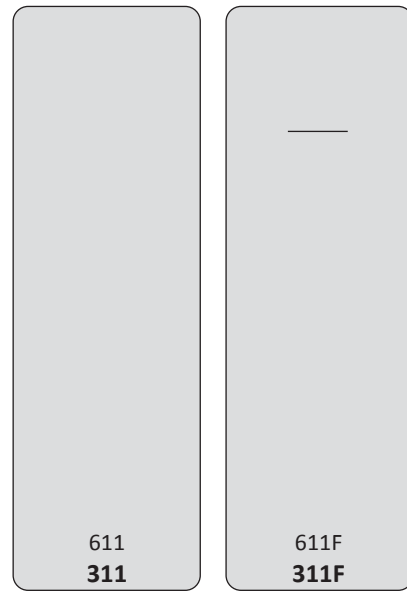

78 x 25 mm

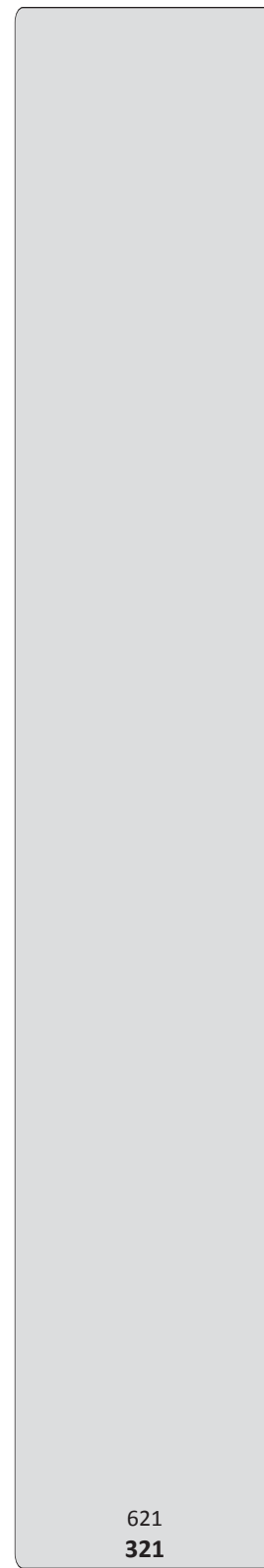

210 x 35 mm

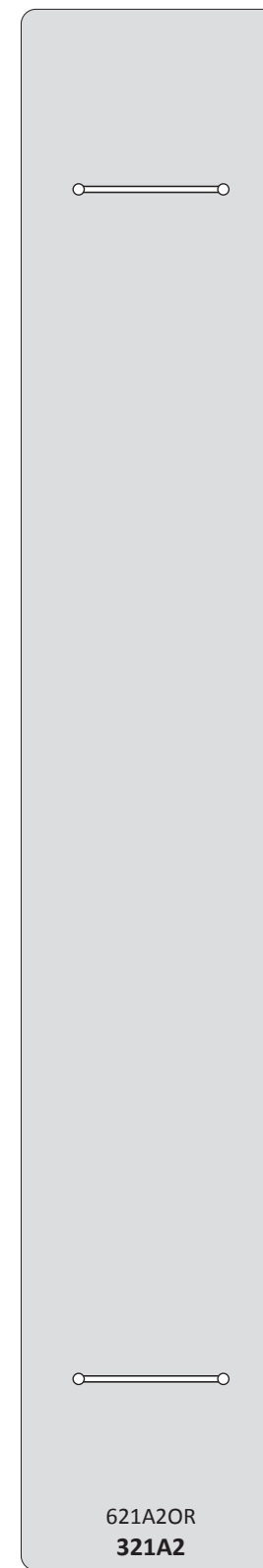

210 x 35 mm

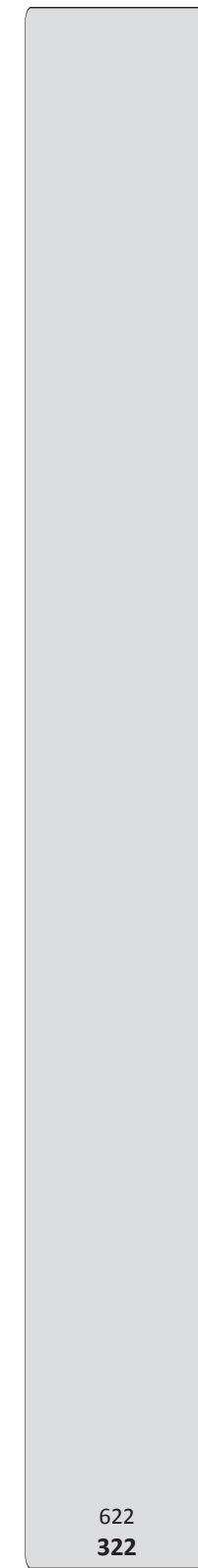

210 x 25 mm

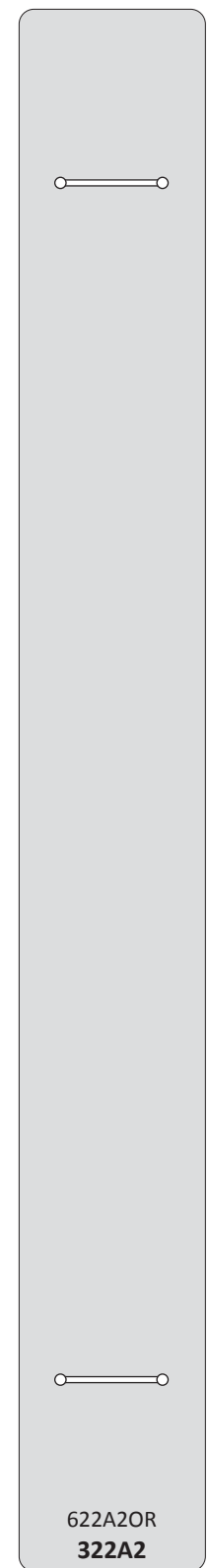

210 x 25 mm

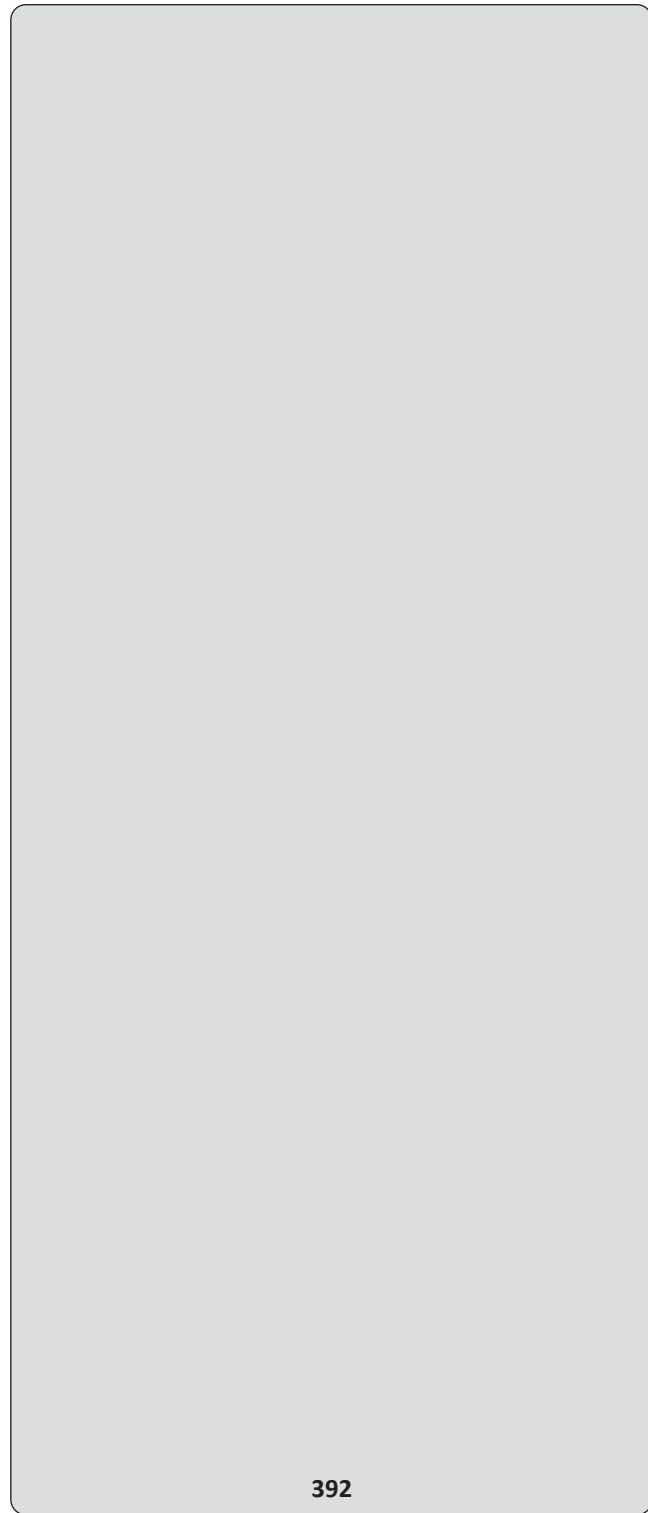

200 x 85 mm

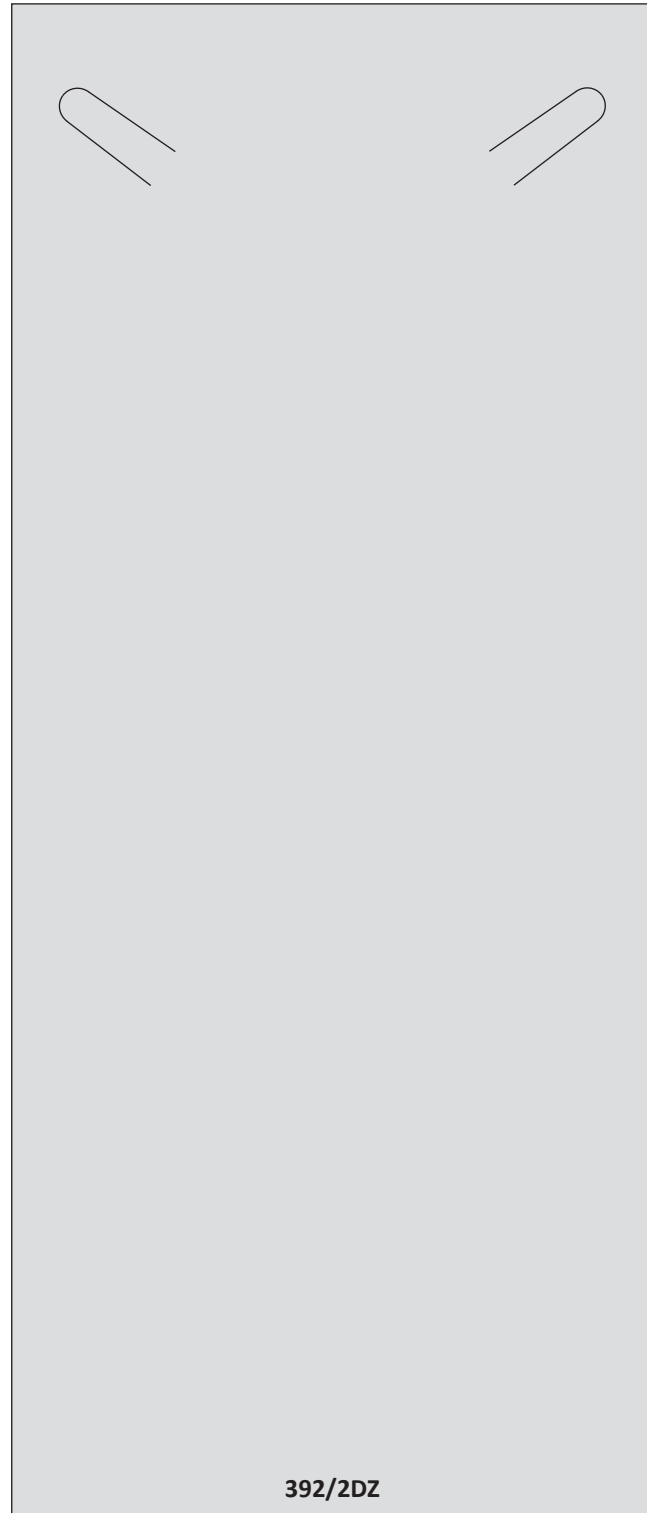

200 x 85 mm

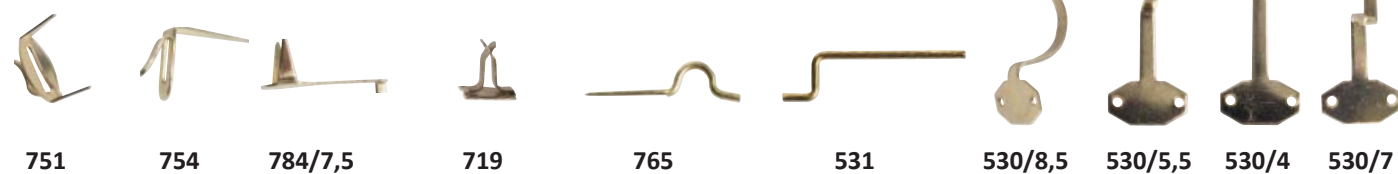

Maßangaben: Länge x Breite x Höhe | Dimensions: Length x Width x Height | Dimensions: Longueur x Largeur x Hauteur

## NADELN

Hochwertige Aufstecknadeln aus deutscher Produktion. Für jede Nadel wird der Qualitäts-Messingdraht beidseitig ange- spitzt, in einem Präzisionswerkzeug gebogen und anschließend entweder anlaufgeschützt oder vernickelt. Durch dieses auf- wendige Fertigungsverfahren ist eine erstklassige Handhabung und Langlebigkeit der Nadeln und Klammern gewährleistet.

German produced pins of high quality brass wire, sharpened on both sides and bent into a precision tool and then either tarnishing or nickel plated. Through this complex production process and first class handling, the durability of all pins and brackets is guaranteed.

Épingles de bijouterie de grande qualité, made in Germany. Chaque tige de fil de laiton de qualité est affûtée des deux côtés et plié dans un outil de précision et ensuite soit ternie soit ni- ckelée. Grâce à ce processus de production complexe, un traite- ment de première classe, la longévité des épingles de bijouterie et des pinces-créoles en est garantie.

Metall-Nadeln, Gold- (G) oder Chromfarben (W)

Metal "U" pins, gilt (G) or chrome (W)

Épingles de bijouterie métalliques dorées (G) ou chromées (W)



**719G**  
**719W**

**Creolen-Klammer**

Creole clip  
pinces-créoles

6 x 6 x 10 mm

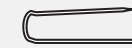

**734G**  
**734W**

16 x 5 mm



**736G**  
**736W**

24 x 7 mm



**737G**  
**737W**

23 x 9 mm



**739G**  
**739W**

21 x 8 mm

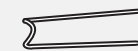

**740G**  
**740W**

17 x 4 mm



**742G**  
**742W**

14 x 7 mm



**743G**  
**743W**

24 x 4 mm



**745G**  
**745W**

23 x 6 mm

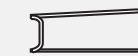

**746G**  
**746W**

16 x 6 mm



**747G**  
**747W**

23 x 6 mm



**748G**  
**748W**

33 x 6 mm

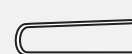

**749G**  
**749W**

19 x 5 mm



**752G**  
**752W**

18 x 6 mm

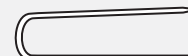

**753G**  
**753W**

26 x 7 mm



PRACTICAL

PROTECTIVE

READY TO DESPATCH

## X-PRESS-BOX

Praktische Kleinteile-Verpackung aus unverwüstlichem Polypropylen. Ein fester Innenrahmen garantiert einen sicheren Packraum. Lieferbare Farben sind: Weiß, Schwarz, Silber-Metallic und Blau-Metallic. Sonderfarben sind ab 10.000 Stück möglich. In allen Boxen, die ab LAGER geliefert werden, befindet sich das KLING-Logo im Innenraum.

This practical small-parts package is made of indestructible Polypropylene. A solid inner frame guarantees secure packing space. Standard stock colours are white, black, metallic silver and metallic blue (stock boxes carry the Kling logo inside). Special colours are possible with quantities of 10.000 pieces.

Emballage en matière plastique inusable, pratique pour toutes petites pièces. Un cadre intérieur stable vous garantit un emballage solide. Couleurs livrables: blanc, noir, métallique et bleu métallique. Autres couleurs à partir de 10.000 pièces. Pour toute livraison du stock, vous trouverez la publicité KLING à l'intérieur de la boîte.

**Packmaß: 98 x 60 x 14 mm**  
Int. comp.: 98 x 60 x 14 mm  
Dim. d'emballage:  
98 x 60 x 14 mm

**111**  
124 x 88 x 17 mm



**Packmaß: 62 x 31 x 10 mm**  
Int. comp.: 62 x 31 x 10 mm  
Dim. d'emballage:  
62 x 31 x 10 mm

**113**  
94 x 64 x 14 mm



Maßangaben: Länge x Breite x Höhe | Dimensions: Length x Width x Height | Dimensions: Longueur x Largeur x Hauteur

**Packmaß: 125 x 84 x 20 mm**  
Int. comp.: 125 x 84 x 20 mm  
Dim. d'emballage:  
125 x 84 x 20 mm

**115**  
148 x 110 x 27 mm



**Packmaß: 125 x 95 x 20 mm,**  
**nur in weiß**  
Int. comp.: 125 x 95 x 20 mm,  
in white only  
Dim. d'emballage: 125 x 95 x 20 mm,  
en blanc seulement

**116KW**  
145 x 120 x 22 mm



**Schaumstoffzuschnitte in weiß,**  
**3 mm**  
Foam inserts in white, 3 mm  
Intérieur mousse blanc, 3 mm

**111E**  
für Box / for box /  
pour boîte no. 111

**113E**  
für Box / for box /  
pour boîte no. 113

**115E**  
für Box / for box /  
pour boîte no. 115 + 116



**Schaumstoffzuschnitte leitfähig schwarz,**  
**6 mm**  
Foam inserts antistatic black, 6 mm  
Intérieur mousse antistatique noir, 3 mm

**111ES**  
für Box / for box / pour boîte no. 111  
weich / soft / molle

**111ES/2**  
für Box / for box / pour boîte no. 111  
hart / hard / dure

**113ES**  
für Box / for box / pour boîte no. 113  
weich / soft / molle

**113ES/2**  
für Box / for box / pour boîte no. 113  
hart / hard / dure

**115ES**  
für Box / for box / pour boîte no. 115 + 116  
weich / soft / molle

**115ES/2**  
für Box / for box / pour boîte no. 115 + 116  
hart / hard / dure



Druckbeispiel / print example / exemple d'impression

## DRUCK AUSSEN & STEMPEL- EINSATZ INNEN AUF ANFRAGE

PRINT AT THE OUTSIDE & EMBOSSEING  
INSIDE ON REQUEST  
IMPRESSION SUR L'EXTÉRIEUR ET MARQUAGE À  
L'INTÉRIEUR SUR DEMANDE

# VITRINEN

SHOWCASES | VITRINES

Vitrinen für Schmuck und Uhren  
Showcases for jewellery and watches  
*Vitrines pour bijoux et montres*

122 - 131



[www.kling.de](http://www.kling.de)



VITRINEN & SHOP IN SHOP KATALOG  
SHOWCASES & SHOP IN SHOP CATALOGUE  
VITRINES & SHOP IN SHOP CATALOGUE

Entdecken Sie eine Vielzahl an Vitrinen und Shop in Shop Systemen in unserem Katalog. Jetzt Online blättern!

Explore a variety of showcases and shop in shop systems in our catalogue. Browse online now!

*Decouvrez nos vitrines et concepts de meubles dans notre catalogue en ligne.*



## VITRINEN

Vitrinen von Kling bilden einen exklusiven Rahmen zur optimalen Präsentation Ihrer Waren. Neben individuell entwickelten Vitrinen bietet Kling Ihnen hochwertige Standardmodelle. Unsere Vitrinenserien bestechen neben Funktionalität durch Ihre schlichte Eleganz und verhelfen Ihnen zu deutlich mehr Verkaufserlösen am Point of Sale. Auf den folgenden Seiten erhalten Sie einen Überblick über unsere Vitrinenserien und deren zahlreichen Individualisierungsmöglichkeiten.

Showcases made by Kling form an exclusive setting for the very best presentation of your products. In addition to individually designed showcases, Kling offers a wide range of high-quality standard models. Our range of showcases stand out through functionality, elegant simplicity and assist you to achieve increased sales revenue at point of sale. On the following pages, you will find an overview of our showcase ranges as well as the many possibilities of customisation available.

*Les vitrines de la société Kling constituent une plateforme idéale pour la présentation optimale des produits. Outre les modèles de vitrines développés conformément aux souhaits individuels du client, Kling propose également des modèles standards de grande qualité. Nos différentes collections et lignes de vitrines séduisent par leur extrême fonctionnalité et leur élégance sobre et vous garantiront l'amélioration de votre CA sur le point de vente. Les pages qui suivent vous donnent un aperçu sur nos différentes collections de vitrines/présentoirs et la variété des configurations possibles.*



Maßangaben: Länge x Breite x Höhe | Dimensions: Length x Width x Height | Dimensions: Longueur x Largeur x Hauteur



**LED-beleuchtete Vitrine für 4x3 BASIC-PLUS-Einsätze (nicht inklusive), manuell drehbar, 4 abschließbare Sicherheits-Glastüren und Unterschrank mit Stauraum, abschließbar, 4 Industrierollen hinter Sockelblende**

LED-illuminated showcase for 4x3 BASIC-PLUS-inserts (not inclusive), manually revolvable, 4 lockable safety glass doors and base with lockable storage, skirting board concealing the 4 casters  
*Vitrine à éclairage LED pour 4x3 inserts thermoformés BASIC-PLUS (à commander séparément), tournant manuellement, 4 portes vitrées sécurisées et placard inférieur verrouillable avec espace de stockage, sur roues (x4)*

**23817B2** 530x530x1920 mm

**Wie 23817B2, jedoch passend für Uhren**

Similar to 23817B2, to fit watch inserts

*Même comme 23817B2, mais approprié aux supports de montres*

**23817B2U** 560x560x1920 mm



**LED-beleuchtete Vitrine für 4x4 BASIC-PLUS-Einsätze (nicht inklusive), manuell drehbar, 4 abschließbare Sicherheits-Glastüren und Sockel mit Stauraum, abschließbar, unter zurückversetztem Kranz 4 Industrierollen mit Feststeller**

LED-illuminated showcase for 4x4 BASIC-PLUS-inserts (not inclusive), manually revolvable, 4 lockable safety glass doors and base with lockable storage, skirting board concealing the 4 casters

*Vitrine à éclairage LED pour 4x4 inserts thermoformés BASIC-PLUS (à commander séparément), tournant manuellement, 4 portes vitrées sécurisées et placard inférieur verrouillable, avec espace de stockage, sur roues (x4 blocables)*

**24573B** 470x470x1870mm



**LED-beleuchtete Vitrine für 4x3 BASIC-PLUS-Einsätze (nicht inklusive), manuell drehbar, 1 Sicherheits-Glastür und Unterschrank mit Stauraum abschließbar, 4 Industrierollen, davon 2 feststellbar**

LED-illuminated showcase for 4x3 BASIC-PLUS-inserts (not inclusive), manually revolvable, 1 lockable safety glass door and lockable base with storage, 4 casters

*Vitrine à éclairage LED pour 4x3 inserts thermoformés BASIC-PLUS (à commander séparément), tournant manuellement, 1 porte vitrée sécurisée et placard inférieur verrouillable, avec espace de stockage, sur roues (x4 dont 2 blocables)*

**21152B** 470x470x1840 mm



**LED-beleuchtete Vitrine für 4x3 BASIC-PLUS-Einsätze (nicht inklusive), drehbarer Innenkorpus mit Motor, 1 Sicherheits-Glastür und Sockel mit Stauraum, abschließbar, 4 Industrierollen**

LED-illuminated showcase for 4x3 BASIC-PLUS-inserts (not inclusive), rotatable inner part (extra strong motor), 1 lockable safety glass door and base with lockable storage, 4 casters

*Vitrine à éclairage LED pour 4x3 inserts BASIC-PLUS (à commander séparément), structure interne rotative avec moteur, 1 porte vitrée sécurisée et placard inférieur verrouillable, avec espace de stockage, sur roues (x4)*

**21150B10** 470x470x1840 mm



**Doppel-Vitrine, LED-beleuchtet, für je 12 BASIC-PLUS-Einsätze (nicht inklusive), manuell drehbar, 2x4 abschließbare Sicherheits-Glastüren und Unterschrank mit Stauraum abschließbar, 5 Industrierollen hinter Sockelblende**

LED-illuminated twin-showcase for 2x12 BASIC-PLUS-watch-inserts (not inclusive), manually revolvable, 4 lockable safety glass doors and base with lockable storage, skirting board concealing the 5 casters

*Vitrine double à éclairage LED pour 2x12 inserts thermoformés BASIC-PLUS (à commander séparément), tournant manuellement, 2x4 portes vitrées sécurisées et placard inférieur verrouillable avec espace de stockage, sur roues (x5)*

**24745B** 1105x530x1920 mm



**Lackierung nach dem RAL-Farbspektrum möglich.**

Possible colours selectable from the RAL spectrum

*Couleur des éléments à sélectionner dans le nuancier RAL*



**Vitrine mit 3 Deko-Ebenen, jede Ebene mit LED-Spot-Beleuchtung, 1 abschließbare Sicherheits-Glastür und Sockel mit Stauraum abschließbar, 4 Industrierollen**

Showcase with 3 layers, each layer LED-illuminated, lockable safety glass door, lockable base with storage, 4 casters

*Vitrine avec 3 étagères, éclairage LED à chaque étagère, 1 porte vitrée sécurisée et placard inférieur verrouillable, avec espace de stockage, sur roues (x4)*

**24760B** 454x454x1825 mm



**Vitrine beleuchtet mit Unterschrank für 144 Uhrspangen (inklusive), 1 abschließbare Sicherheits-Glastür und Sockel mit Stauraum abschließbar, Innenkorpus elektrisch drehbar, extra starker Motor**

LED-illuminated showcase for 144 watch supports (inclusive), electrical rotating inner part (extra strong motor), 1 lockable safety glass door and lockable base with storage

*Vitrine en verre éclairée avec espace de rangement, pour 144 supports de montres, intérieur à rotation électrique - moteur extra puissant*

**20750B9** 470x470x1840 mm

Maßangaben: Länge x Breite x Höhe | Dimensions: Length x Width x Height | Dimensions: Longueur x Largeur x Hauteur



**LED-beleuchtete Vitrine für 4x4 Einsätze (nicht inklusive), elektrisch drehbarer Innenkorpus (extra starker Motor), 1 Sicherheits-Glastür und Sockel mit Stauraum abschließbar, 4 Industrierollen**  
LED-illuminated showcase for 4x4 inserts (not inclusive), electrical rotating inner part (extra strong motor), 1 safety glass door and base with storage lockable, 4 casters  
*Vitrine en verre éclairée avec espace de rangement, pour 4x4 inserts (non compris), intérieur à rotation électrique - moteur extra puissant*

**24089B** 500x500x1900 mm



**Schale für Einsätze**  
Poly back to take inserts  
*Bac en poly pour inserts thermoformés*

**2577Wi1#** 255 x 255 mm



**Einsatz mit 36 Fächer (35 x 35 mm), vertieft**  
Insert with 36 compartments (35 x 35 mm), deep-set  
*Insert thermoformé avec 36 compartiments surélevés (35 x 35 mm)*

**2438** 255 x 255 mm



**Einsatz mit 24 Fächer (55 x 38 mm), vertieft**  
Insert with 24 compartments (55 x 38 mm), deep-set  
*Insert thermoformé avec 24 compartiments surélevés (55 x 38 mm)*

**2576** 255 x 255 mm



**Einsatz mit 5 Fächer, 15 Haken**  
Insert with 5 compartments, 15 hooks  
*Insert thermoformé avec 5 compartiments, 15 crochets*

**20058S** 255 x 255 mm



**Lackierte Vitrine mit 3 Deko-Ebenen, jede Ebene mit LED-Beleuchtung und abschließbarer Tür, Sockel mit abschließbarer Tür und einem verstellbaren Fachboden**  
Lacquered showcase with 3 layers, each layer LED-illuminated and lockable safety glass door, lockable base with storage, skirting board concealing the 4 casters  
*Vitrine laquée à 3 niveaux, éclairage LED et porte verrouillable à chaque niveau, porte verrouillable dans le socle de la vitrine et 1 étagère ajustable*

**23396B2** 500x500x1900 mm



**Ringobar für 45 Ringe, lackiert, 1 abschließbare Tür, zzgl. Sicherungselemente**  
Ringobar for 45 rings, lacquered wooden frame with lockable security glass door, 4 casters, security elements not inclusive  
*Ringobar pour 45 bagues, laqué, 1 porte vitrée verrouillable, éléments de sécurité à commander séparément*

**21750R** 372x372x1150 mm



**Ringobar für 100 Ringe, 1 abschließbare Tür, zzgl. Sicherungselemente, 4 Industrierollen**  
Ringobar for 100 rings, 1 lockable door (security elements not inclusive), 4 casters  
*Ringobar pour 100 bagues, 1 porte verrouillable, éléments de sécurité à commander séparément*

**21751/3R** 438x398x1000 mm



**Ringobar für 90 Ringe, Unterschrank mit abschließbarer Tür, Stauraum und einem Fachboden, zzgl. Sicherungselemente 20960D1**  
Ringobar for 90 rings, lockable base with storage shelf, security elements 20960D1 not inclusive  
*Ringobar, modèle sur pieds pour 90 bagues. Plus éléments de sécurité 20960D1*

**20965** 370x370x1050 mm



**Ringobar für 90 Ringe mit abschließbarer Tür, zzgl. Sicherungselemente**  
Ringobar for 90 rings, lockable door, security elements not inclusive  
*Ringobar pour 90 bagues, placard inférieur à une étagère avec porte verrouillable, éléments de sécurité à commander séparément*

**21310/4** 372x372x1060 mm

**Ringobar für 45 Ringe mit abschließbarer Tür, zzgl. Sicherungselemente**  
Ringobar for 45 rings, lockable door, security elements not inclusive  
*Ringobar pour 45 bagues, placard inférieur à une étagère avec porte verrouillable, éléments de sécurité à commander séparément*

**21310/1** 372x372x1060 mm



**Tisch-Ringobar (Plexiglas) für 25 Ringe, 1 abschließbare Tür, zzgl. Sicherungselemente**  
Acrylic-Counter-Ringobar for 25 rings, 1 lockable door, security elements not inclusive  
*Ringobar de comptoir (en plexi) pour 25 bagues, 1 porte verrouillable, éléments de sécurité à commander séparément*

**22477** 242x242x315 mm



**Sicherungselement für Ringobar, kunststoffummanteltes Stahlseil, VPE 10 Stk.**  
Security elements for ring presentation system, packing unit 10 pieces.  
*Éléments de sécurité pour présentoir pour bagues, unité d'emballage 10 pièces*

**Länge / length / longueurs**

<b>20960D1</b>	<b>320 mm</b>
<b>20960D1L</b>	<b>960 mm</b>



Maßangaben: Länge x Breite x Höhe | Dimensions: Length x Width x Height | Dimensions: Longueur x Largeur x Hauteur













**Einsätze und Karten für Vitrinen | Inserts and pads for showcases | Inserts thermoformés et cartes pour vitrines**

**Vitrinen Showcases Vitrine**

**23817B2**  
**23817B2U**  
**24745B**  
**21152B**  
**21150B10**

**Poly-Schale** Poly back Bac en poly  
**Einsätze** Compartments Inserts thermoformés  
**Karten** Pads Carte

Einsätze erhältlich in weiß, schwarz, grau | Compartments available in white, black, grey | Inserts thermoformés disponibles en blanc, noir, gris

 <p><b>2 Fächer</b> 2 compartments 2 compartiments</p> <p><b>3013</b> 330 x 220 mm</p>	 <p><b>18 vertiefte Fächer (70 x 45 mm) für Kartenserie 301...</b> 18 deep compartments (70 x 45 mm) for Pad series 301... 18 compartiments surélevés (70 x 45 mm) pour Carte série 301...</p> <p><b>3149V</b> 330 x 220 mm</p>
 <p><b>8 vertiefte Fächer (105 x 75 mm) für Kartenserie 380...</b> 8 deep compartments (105 x 75 mm) for Pad series 380... 8 compartiments surélevés (55 x 38 mm) pour Carte série 380...</p> <p><b>3011V</b> 330 x 220 mm</p>	 <p><b>22 vertiefte Fächer (78 x 25 mm) für Kartenserie 311, 311f</b> 22 deep compartments (78 x 25 mm) for Pad series 311, 311f 22 compartiments surélevés (78 x 25 mm) pour Carte série 311, 311f</p> <p><b>3164</b> 330 x 220 mm</p>
 <p><b>8 Fächer für Kartenserie 321...</b> 8 compartments for Pad series 321... 8 compartiments pour Carte série 321...</p> <p><b>3008</b> 330 x 220 mm</p>	 <p><b>28 vertiefte Fächer (78 x 25 mm) für Kartenserie 311, 311f</b> 28 deep compartments (78 x 25 mm) for Pad series 311, 311f 28 compartiments surélevés (78 x 25 mm) pour Carte série 311, 311f</p> <p><b>3066</b> 330 x 220 mm</p>
 <p><b>11 Fächer für Kartenserie 322...</b> 11 compartments for Pad series 322... 11 compartiments pour Carte série 322...</p> <p><b>3007</b> 330 x 220 mm</p>	 <p><b>24 vertiefte Fächer (55 x 38 mm) für Kartenserie 302...</b> 24 deep compartments (55 x 38 mm) for Pad series 302... 24 compartiments surélevés (55 x 38 mm) pour Carte série 302...</p> <p><b>3014V</b> 330 x 220 mm</p>
 <p><b>12 vertiefte Fächer (78 x 55 mm) für Kartenserie 308...</b> 12 deep compartments (78 x 55 mm) for Pad series 308... 12 compartiments surélevés (78 x 55 mm) pour Carte série 308...</p> <p><b>3001V</b> 330 x 220 mm</p>	 <p><b>25 vertiefte Fächer (55 x 38 mm) für Kartenserie 302...</b> 25 deep compartments (55 x 38 mm) for Pad series 302... 25 compartiments surélevés (55 x 38 mm) pour Carte série 302...</p> <p><b>3003V</b> 330 x 220 mm</p>
 <p><b>16 vertiefte Fächer (70 x 45 mm) für Kartenserie 301...</b> 16 deep compartments (70 x 45 mm) for Pad series 301... 16 compartiments surélevés (70 x 45 mm) pour Carte série 301...</p> <p><b>3002V</b> 330 x 220 mm</p>	 <p><b>30 vertiefte Fächer (45 x 35 mm) für Kartenserie 303...</b> 30 deep compartments (45 x 35 mm) for Pad series 303... 30 compartiments surélevés (45 x 35 mm) pour Carte série 303...</p> <p><b>3084V</b> 330 x 220 mm</p>

 <p><b>32 vertiefte Fächer (45 x 35 mm) für Kartenserie 303...</b> 32 deep compartments (45 x 35 mm) for Pad series 303... 32 compartiments surélevés (45 x 35 mm) pour Carte série 303...</p> <p><b>3004V</b> 330 x 220 mm</p>	 <p><b>40 vertiefte Fächer (35 x 35 mm) für Kartenserie 328...</b> 40 deep compartments (35 x 35 mm) for Pad series 328... 40 compartiments surélevés (35 x 35 mm) pour Carte série 328...</p> <p><b>3016V</b> 330 x 220 mm</p>
 <p><b>48 vertiefte Fächer (35 x 30 mm) für Kartenserie 332...</b> 48 deep compartments (35 x 30 mm) for Pad series 332... 48 compartiments surélevés (35 x 30 mm) pour Carte série 332...</p> <p><b>3081V</b> 330 x 220 mm</p>	 <p><b>45 vertiefte Fächer (35 x 30 mm) für Kartenserie 332...</b> 45 deep compartments (35 x 30 mm) for Pad series 332... 45 compartiments surélevés (35 x 30 mm) pour Carte série 332...</p> <p><b>3015V</b> 330 x 220 mm</p>
 <p><b>18-er Hakenleiste (gold-/silberfarben)</b> Strip of 18 hooks (gilt/chrome) Barre avec 18 crochets, (dorés/argentés)</p> <p><b>3079</b> 330 x 220 mm</p>	 <p><b>Schaumstoffeinlage für 104 Ringe</b> Foam insert for 104 rings Mousse avec 104 fentes pour bagues</p> <p><b>3023/104</b> 330 x 220 mm</p>
 <p><b>40 Ringe</b> 40 rings 40 bagues</p> <p><b>3082H</b> 330 x 220 mm</p>	 <p><b>Poly-Schale mit Winkel</b> Poly back with angle Boîtier en polyester-avec angle</p> <p><b>3090Wi1#</b> 330 x 220 mm</p>

Aufsteckkarten Pads Cartes	Stanzungen Designs Perforations	
Anhänger/Brosche pendant/brooch pend./broche		Glatt Plain Lisse
Stecker drop stud earrings Clous d'oreilles		...iH
		...iQ ...iQ/M
		...i
Stecker, Lochstanzung 6 mm vom Rand drop stud earrings, punching 6 mm from top Clous d'oreilles, perforation à 6 mm du bord		...iH/6
Anhänger (Haken 751) pendant (Hook 751) Pend. (Crochet 751)		...HA
Anhänger (Haken 765) pendant (Hook 765) Pend. (Crochet 765)		...HA9
Haken 530/8,5 Hook 530/8,5 Crochet 530/8,5		...HA2
Boutons drop earrings Dormeuses		...DH
		...D
Manschettenknöpfe Cufflinks Boutons de manchettes		...A4
Clips Clips Clips		...B3H
		...B3Q
Creolen (+ Klammer 719) Creole earrings (+ clip 719) Créoles (+ clip 719)		...C2Q
Ketten mit Anhänger Chain with pendant Chaîne avec pend.		...TH
		...TQ
Winkelkarte für Stecker Angle Pad for drop stud earrings Carte recourbée pour clous d'oreilles		...WiH
		...WiQ
Krawatten-Nadeln Tie-pin Pincés à cravate		311 78 x 25 mm
		311f 78 x 25 mm

# VITRINE MIT AKKUBETRIEBENER BELEUCHTUNG

SHOWCASE WITH BATTERY-POWERED LIGHTING |  
METTRE EN VALEUR UNE VITRINE AVEC UN ÉCLAIRAGE  
ALIMENTÉ PAR BATTERIE

- ✓ Beleuchtung optional mit 12V Akku oder mit 220V Stromversorgung für 14 Stunden Beleuchtung.
- ✓ Dimmbare Beleuchtung
- ✓ Integrierte Komplettlösung, inkl. Ladestation
- ✓ Austauschbare Akkueinheit
- ✓ Für Dauereinsatz im Ladengeschäft & auf Messen
  
- ✓ Dimmable illumination for 14-hours lighting: optional with 12V battery or 220V power supply
- ✓ Integrated package solution and charging station
- ✓ Battery removable
- ✓ Continuous operation for retail shop and trade fairs
  
- ✓ *éclairage en option: à l'aide soit d'une batterie 12V soit d'une alimentation en courant de 220V pour 14h d'éclairage.*
- ✓ *Eclairage réglable*
- ✓ *solution complète intégrée avec station de recharge*
- ✓ *batterie interchangeable*
- ✓ *pour une utilisation continue dans un magasin ou sur salon*



NEW

INNOVATIVE SYSTEM

MADE IN GERMANY



LED-Röhren  
LED-tube  
Tube LED



LED-Einbauleuchte  
Built-in LED-spotlight  
Lampe encastrée LED



LED-Stab-  
leuchte  
LED-bar  
éclairage  
tubulaire à  
LED



LED-Spot  
LED-spotlight  
Spot à LED











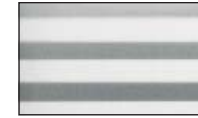

## INS RICHTIGE LICHT SETZEN - BELEUCHTUNGSSYSTEME

Attraktive Beleuchtungssysteme sind in der verkaufswirksamen Warenpräsentation unentbehrlich. Kling bietet Ihnen deshalb professionelle & verkaufsfördernde Lichtlösungen auf dem aktuellsten Stand der Technik, mit hoher und langlebiger Qualität an. Ganz neu in unserem Portfolio finden Sie akkubetriebene Beleuchtungssysteme. Mit diesem innovativen System können Sie Ihre Vitrine bis zu 14 Stunden ohne Netzstrom betreiben.

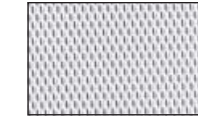
**Put in the right light - lighting systems.** Effective presentation needs an attractive illumination system. Kling offers you professional and supporting light solutions - up-to-date, high and long-lasting quality. In our product portfolio you will find battery-operated lighting systems. With this innovative system your showcase can be plugged in operation up to 14 hours.

**Systèmes d'éclairage - valoriser un produit.** Exposer dans une vitrine grâce à un système d'éclairage approprié est indispensable. KLING vous propose des solutions professionnelles d'éclairage à la pointe du progrès technologique favorisant les ventes de vos produits, comme par exemple nos tous nouveaux systèmes innovatifs d'éclairage de vitrines avec batterie d'une autonomie de près de 14h, sans alimentation électrique secteur.

## Kofferoberflächen | Exterior Case Covering | Gainerie extérieure des marmottes

 <b>50206</b> Schwarz   black   noir	 <b>51805</b> Grau   grey   gris	 <b>51200</b> Schwarz   black   noir	 <b>76121</b> Alu Natur hochglanz High gloss natural aluminium Aluminium naturel brillant	 <b>76203</b> Schwarz matt Matt black Noir mat	 <b>76122</b> Silber-metallic Metallic silver Argent métallique
 <b>77120</b> Silber-metallic Metallic silver Argent métallique	 <b>77803</b> Anthrazit-metallic Metallic anthracite Anthracite métallisé	 <b>77153</b> Dunkelblau-metallic Metallic dark-blue Bleu foncé métallisé	 <b>77300</b> Weiß   white   blanc	 <b>77200</b> Schwarz   black   noir	

## Ladenbezüge | Interior fittings and pads | Gainerie Intérieure et coussinets

### STANDARD

 <b>51200</b> Schwarz   black   noir	 <b>51800</b> Grau   grey   gris	 <b>51805</b> Grau   grey   gris	 <b>84800</b> Grau   grey   gris	 <b>84201</b> Schwarz   black   noir	
 <b>84203</b> Schwarz   black   noir	 <b>84130</b> Rot   red   rouge	 <b>84191</b> Bordeaux   burgundy   bordeaux	 <b>84151</b> Safir   sapphire   saphir	 <b>84207</b> Schwarz   black   noir	 <b>84107</b> Braun   brown   marron
 <b>83202</b> Anthrazit   anthracite   anthracite	 <b>83203</b> Carbon   carbon   carbone	 <b>84111</b> Koralle   coral   corail	 <b>84154</b> Indigo   indigo   indigo	 <b>84108</b> Braun   brown   marron	 <b>84208</b> Schwarz   black   noir
	 <b>17204</b> Schwarz   black   noir	 <b>17405</b> Cream   cream   crème	 <b>17804</b> Anthrazit   anthracite   anthracite		

### DE LUXE















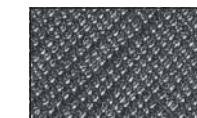

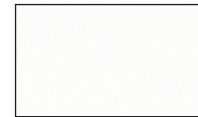
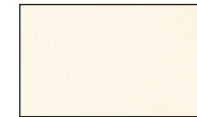
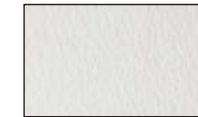
## Aufmachungen | Interior fittings and pads | Gainerie Intérieure et coussinets

### STANDARD

 <b>40200</b> Pic Schwarz   black   noir	 <b>40800</b> Pic Grau   grey   gris	 <b>40803</b> Pic Dunkelgrau   dark grey   gris foncé	 <b>40806</b> Pic Grau   grey   gris	 <b>40172</b> Pic Petrol   petrol   pétrole	 <b>40180</b> Pic Sand   sand   sable
 <b>40401</b> Pic Beige   beige   beige	 <b>40402</b> Pic Crème   cream   crème	 <b>40152</b> Pic Blau   blue   bleu	 <b>40151</b> Pic Blau   blue   bleu	 <b>40150</b> Pic Blau   blue   bleu	 <b>40157</b> Pic Königsblau   royal blue   bleu royal
 <b>40809</b> Pic Dunkelgrau   dark grey   gris foncé	 <b>40130</b> Pic Rot   red   rouge	 <b>40300</b> Pic Weiß   white   blanc	 <b>40154</b> Pic Hellblau   light blue   bleu clair		

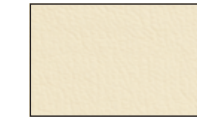
Weitere Farben auf Anfrage | Further colours upon request | Autres couleurs sur demande

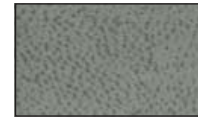
### DE LUXE

 <b>22200</b> Domy Schwarz   black   noir	 <b>22300</b> Domy Weiß   white   blanc	 <b>17405</b> Echo Champagner   champagne   champagne	 <b>17204</b> Echo Ruß   carbon black   Noir de carbone	 <b>17804</b> Echo Palladium   palladium   palladium	 <b>17120</b> PU Silber   silver   argent
 <b>64207</b> Quinel Schwarz   black   noir	 <b>64307</b> Quinel Weiß   white   blanc	 <b>64303</b> Quinel Crème   cream   crème	 <b>64809</b> Quinel Hellgrau   light grey   gris clair	 <b>64400</b> Quinel Beige   beige   beige	 <b>64804</b> Quinel Anthrazit   anthracite   anthracite
 <b>17201</b> Casablanca Onyx	 <b>17300</b> Casablanca Weiß   white   blanc	 <b>17403</b> Casablanca Peanut	 <b>17103</b> Casablanca Schoko   chocolate   chocolat	 <b>17407</b> PU Flamingo   flamingo   flamant	
 <b>79400</b> Elite Sesam   sesame   sésame	 <b>79800</b> Elite Graphite	 <b>79801</b> Elite Grau   charcoal   charbon			

## Tiefgezogene Einsätze | Vacuum formed inserts | Inserts thermoformés



**20200**  
Velourfolie  
Schwarz | black | noir

**20800**  
Velourfolie  
Grau | grey | gris

**20300**  
Velourfolie  
Weiß | white | blanc

## Taftfächer | Taffeta compartments | Compartiments taffetas

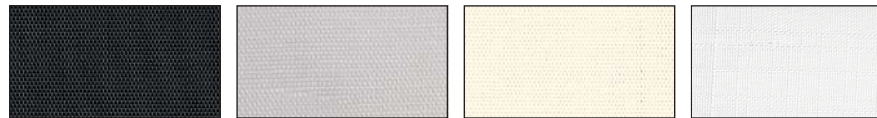

**27200**  
Taft  
Schwarz | black | noir

**27800**  
Taft  
Grau | grey | gris

**27400**  
Taft  
Creme | cream | crème

**44301**  
Calisto  
Weiß | white | blanc

# SERIE REBRA | REBRA SERIES | SÉRIE REBRA

**Standardfarben (ab Lager lieferbar)**  
Standard colours (delivery ex stock)  
Couleurs standard (disponibles en stock)



**80150**  
ABS  
Blau | blue | bleu

**80200**  
ABS  
Schwarz | black | noir

**80800**  
ABS  
Hellgrau | light grey | gris clair

**Individuelle Farben auf Anfrage**  
Individual colours on request  
Couleurs individuelles sur demande

## Karten | Pads | Coussinets

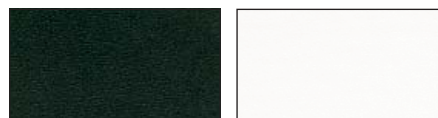

**22200**  
Domy  
Schwarz | black | noir

**22300**  
Domy  
Weiß | white | blanc

Bitte beachten Sie | Please notice | Prière de noter

**Geringfügige Maßabweichungen sind vorbehalten.**  
The dimensions may deviate slightly.  
Sous réserve de variation dans les dimensions



FREE CALL  
00800 48880888

Wir unterstützen Sie gerne bei der Entwicklung Ihrer individuellen Präsentationslösung!

We are pleased to support you with the development of your customised product presentation system.

*Nous vous assistons dans le développement d'une solution sur mesure de la présentation de vos produits.*

**KLING**  
DISPLAY + PACKAGING

**KLING GMBH**

Carl-Benz-Str. 14-16  
75217 Birkenfeld / Germany

Tel.: +49 (0) 7231 4888-0  
Fax: +49 (0) 7231 4888-88  
eMail: [service@kling.de](mailto:service@kling.de)

[www.kling.de](http://www.kling.de)

KLING seit 1928 | Kling since 1928 | KLING depuis 1928  
Ein Unternehmen der Kling Gruppe | Member of the Kling Group | Une entreprise du groupe Kling